



K&K Systems, inc.
Traffic Safety Products Manufacturer



CHANGEABLE MESSAGE SIGN OPERATING MANUAL



TABLE OF CONTENTS

Thank You	4
Introduction	5
Components	6
Precautions, Safety, and Maintenance	8
Vehicle Mount Mounting Holes.....	10
Towing and Long-Term Storage	12
Trailer Setup.....	13

PROGRAMMING

Introduction	14
Terminology	14
Quick Selection Thumb Wheel.....	14

KEYBOARD PROGRAMMING

Create a Changeable Message.....	15
Selecting Fonts.....	16
Make a Message Flash	16
Display a Permanent Message	17
Create and Edit a Changeable Multi-Page Message Sequence	18
Create a Message Sequence/Multi-Page Message with Permanent and Changeable Messages	19
Status	20
Configuration	20
Schedule	20
Permanent Message List: Text	21-23
Permanent Arrow Graphics for 2-Line and Full Matrix.....	24
Full Matrix Permanent Graphics	23-25
Custom Message Log	64-65

WIRELESS PROGRAMMING

Wireless Programming Introduction.....	28
Description of CrossTalk Cross Walk Controls	29
CrossTalk Online Software.....	30
Locations	31
Message Commander.....	32
Preset Messages.....	33
Custom Messages	34
Arrow Modes	35
Settings.....	36
Control.....	37



BLUETOOTH TABLET PROGRAMMING

Bluetooth Tablet Software.....	38
Tablet Operation	38
Description of Tablet Controls	39
Tablet Programming	
Connecting to the Message Sign.....	40
Create a Message.....	40
Create a Sequence/Multi-Page Message	41
Using Graphics	41
Edit a Message	41
Formatting Text	42

PARTS LIST

.....	43
-------	----

TROUBLESHOOTING

Vehicle Mount Troubleshooting.....	44
Trailer Mount: Keyboard Troubleshooting	46
Trailer Mount: Wireless Troubleshooting.....	48

FUSES AND BATTERIES

Fuse Location and Replacement	50
Keyboard Battery Location and Replacement	51

WIRING DIAGRAMS

Vehicle Mount: Controller.....	52
Vehicle Mount: Message Sign.....	53
Trailer Mount Keyboard: Controller	54
Trailer Mount Keyboard: Battery Box	55
Trailer Mount Wireless: CrossTalk XL.....	56
Trailer Mount Wireless: Message Sign.....	57

DIP SWITCHES

Model MB14281: 9001	58
Model MB3L: 9002.....	59
Models MB8249 and MB9757: 9003.....	60

CUSTOM MESSAGE LOG

.....	61-62
-------	-------

WARRANTY

.....	63
-------	----



THANK YOU FOR YOUR BUSINESS!

To Our Valued Customer,

K&K Systems, Inc. is excited that you have purchased our product.

Our company has been serving the traffic industry since 1997. Since that time we have risen to become a leader in the traffic industry. We offer a complete line of traffic safety products that include Message Signs, Arrow Boards, Radar Speed Monitors, Solar School Zone Systems, Wrong Way Systems, and many other quality products that serve our industry today.

At K&K Systems, Inc., we strive to improve the quality of our products. We are dedicated to the concept that our customers are our most valuable resource. We strive to serve our customers as we would want to be served.

Tim Keith,
President



INTRODUCTION

The K&K Systems' Message Sign is a mobile message sign that is static mounted onto a service vehicle or a trailer with winch type or hydraulic lift. They utilize energy efficient LED displays and the latest and most efficient solar panels to display your message brightly during the day, night, rain, snow, and sleet continuously.

All units are completely setup and ready for use. Program your message using wireless connectivity and the K&K cloud-based CrossTalk software, Bluetooth connected tablet with installed software, or the on-board qwerty keyboard. Super bright LED technology with 100,000 hour rating displays alphanumeric text and full matrix graphics with quick message selection switch.

K&K's units are fabricated from aluminum with a flat black powder coat finish to give a smooth look and prevent rust.

The standard Vehicle Mounted Message Sign features a folding frame operated by an actuator. The message sign folds out automatically when the unit is powered on, and automatically folds down when the unit is powered off for when the vehicle is moving. Maintenance of internal parts is made easy with the front door access design. Vehicle Mounted Message Signs are available in your choice of one-line, two-line, and three-line with mounting options and sizes to meet your needs.

Should K&K not have a system that meets your needs, we will custom design a system to meet your specifications



COMPONENTS

TRAILER MOUNT POWER SOURCE

Our products incorporate a battery pack wired for 12 volt operation. The number of batteries may vary depending on the requirements of the design. The system comes standard with four (4) 12 volt sealed batteries, totaling 400 amps, or two (2) 12 volt batteries, totaling 200 amps. The units come with 140 watts of solar, standard. The battery bank is regulated and protected by a solid-state charge controller/low voltage disconnect that is built into the CrossTalk. This prevents gassing and over discharging of the batteries, which can result in premature failure.

VEHICLE MOUNT POWER SOURCE

The truck mounted message board comes standard with a 25ft power cable that is to be integrated into the vehicles existing power system. The smart controller prevents the message board from draining the vehicles battery while it is in the OFF mode during storage. The arrow board is designed to be operated while the vehicles engine is on, to prevent the draining of its battery, but can be operated sparingly while the vehicle is off.

TRAILER BATTERY BOX

The ventilated battery box is steel fabricated with a top mount lid that is sealed with hardware to protect the batteries, charger, and hydraulic system.



Battery Box

CONTROL BOX AND CONTROLLERS

The control box contains the control panel, on/off switch, main processing unit, keyboard and solar charge controller, Bluetooth tablet, and CrossTalk Controller. The control box is constructed of heavy duty aluminum and is weatherproof to protect its components.



MESSAGE SIGN

The display housing is framed in extruded aluminum and has a Lexan face that provides UV protection along with glare resistance. The message sign uses LED (light emitting diodes) to produce text and images.

Your Trailer Mounted Message Sign provides messaging functionality to display predefined and custom messages text. Full Matrix Message Signs can also display MUTCD graphics and animations. To catch motorists' attention we include an option to make the message flash.



TRAILER

The trailer is fabricated from tubular steel with a tubular steel axle. It is powder coated with safety orange, black or white. Custom colors are available upon request. Adjustable jacks are mounted at each corner of the trailer. The tongue features a wheeled jack. The taillights are dual combination reflective lights with stop, tail, and turn signal. Trailers come standard with five lug appropriately sized wheels and tires.



PRECAUTIONS, SAFETY, AND MAINTENANCE

The following are K&K Systems' recommendations for safe and responsible use. Please remember that the best assurance against accidents is a careful and responsible operator.

PRECAUTIONS

Inspect your unit upon delivery. Wires and plugs may have loosened during shipment which will cause operational issues. Even though the system arrives ready to run, inspect all components and test before installation. Test the unit before installation for convenient working conditions.

- Periodically inspect the trailer and/or unit. This includes but not limited to wheels, tongue, pins, safety chains, taillights, nuts, bolts, cable clamps, etc. Tighten, repair, or replace when and where necessary.
- Off-load traffic cones and barricades prior to message sign deployment.
- The trailer should always be properly setup and leveled with the jack stands before the message sign is raised.
- Always use safety chains and properly sized hitch ball when towing the unit.
- Always tow trailer units in the down position.

BATTERIES

The batteries are sealed. Check all terminals for proper connection, tightness, and corrosion. Check the battery condition and charge when necessary or after storage. It is recommended that the batteries be charged every 3 to 6 months, regardless of weather conditions. Use an apron, gloves, and safety glasses when working on batteries. When the batteries have come to the end of their life cycle, please dispose of them in accordance with your local laws and regulations.

BATTERY CHARGER SAFETY

The battery charger is preset in automatic position. **DO NOT CHANGE THESE SETTINGS** because of possible overcharging of batteries. Plug cord into a standard 120 volt AC for charging.

SOLAR PANELS

During operation, keep the solar panel clean of excessive dirt and debris by using only soapy water and a soft cloth or sponge. Periodically check the integrity of the wiring connections in the junction box. Inspect for signs of damage to the solar panel's glass or frame.



MAINTENANCE

- K&K recommends that the user clean the solar panels every 6 months. Over time the solar panels may build up a thin layer of dust/dirt/road grime that can adversely affect their efficiency significantly.
- Check the battery every 6 months to ensure proper charging. If below 12.3 volts, charge to keep power reserves high. Check solar system by cleaning the panel and inspecting wiring for wear and secure connection.
- Check that the mounting is secure and has not shifted as the solar panel may shift direction over time. Ensure the panel is facing South.
- Check the system a few days after installation to ensure proper charging and operation.



Model 8249



VEHICLE MOUNT MOUNTING HOLES

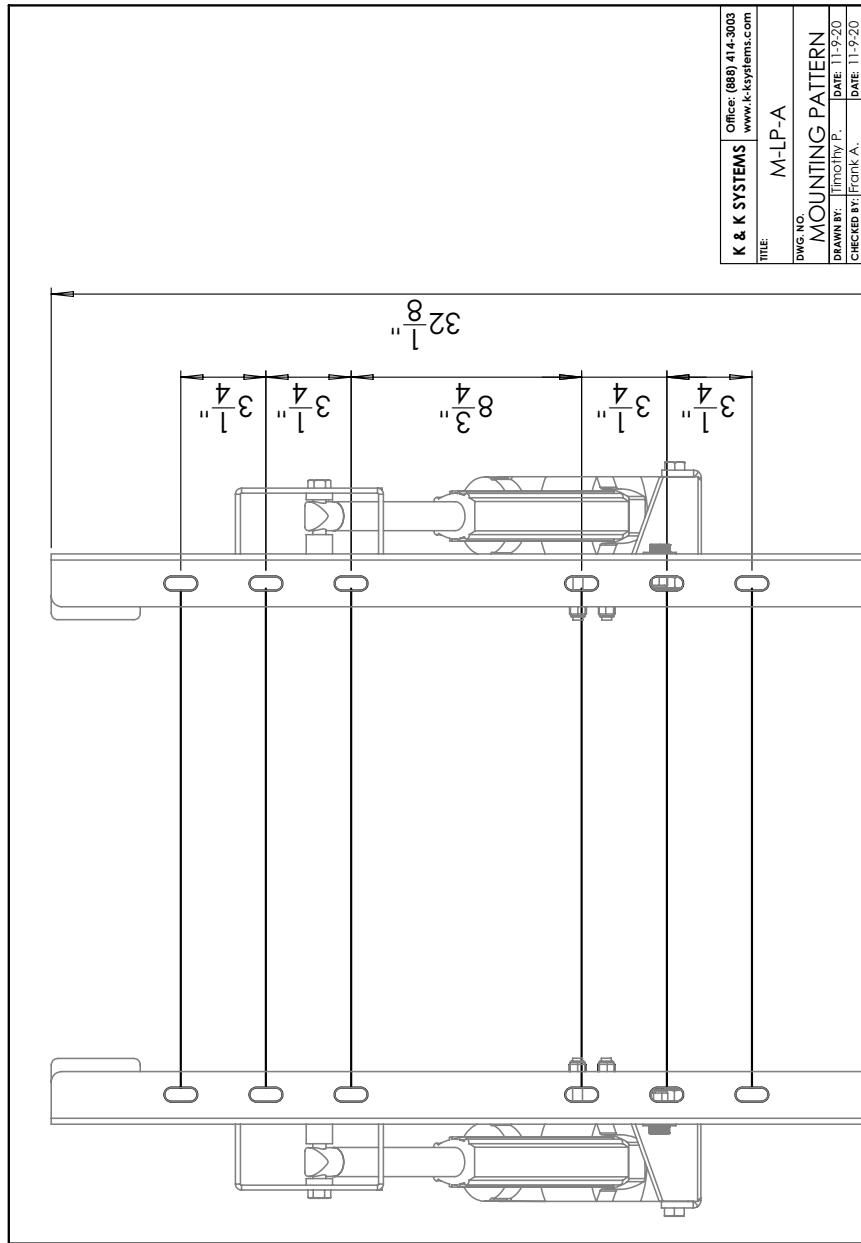
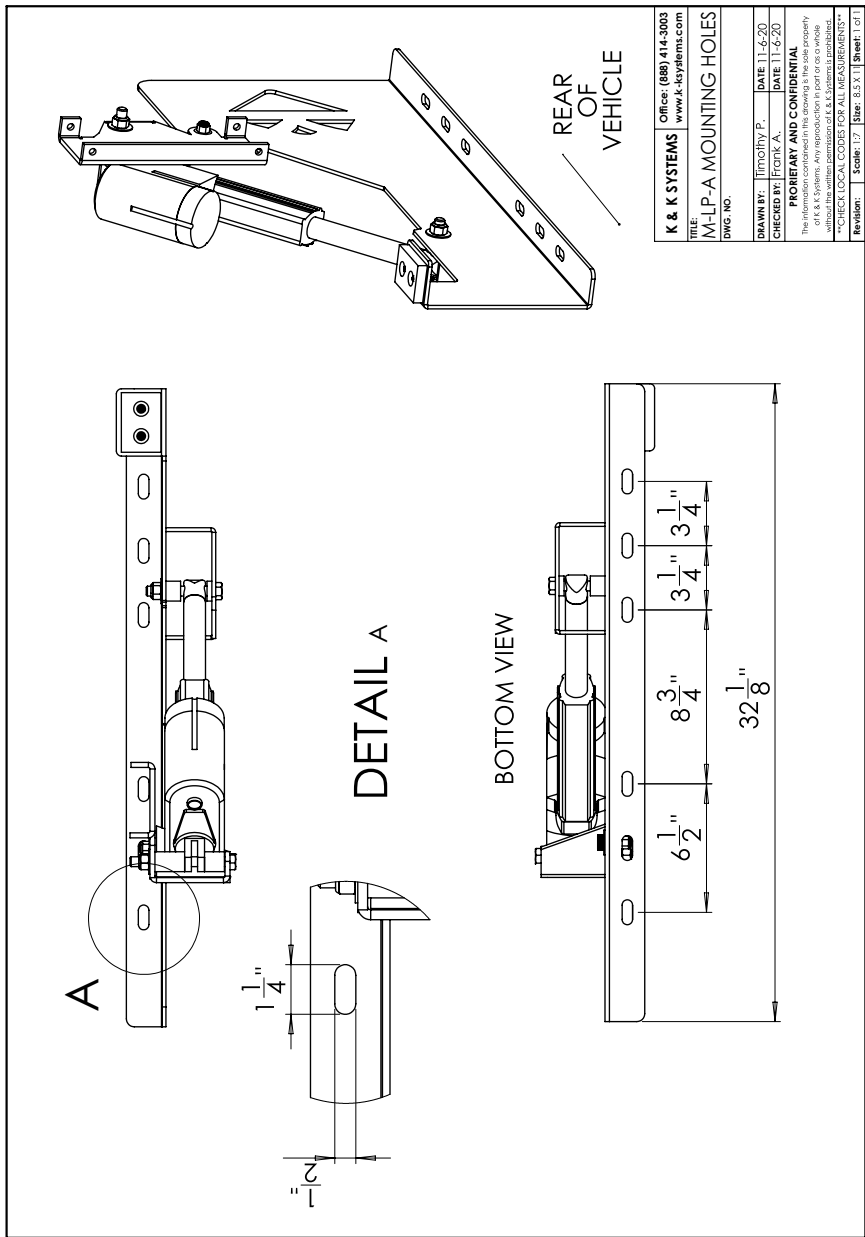



TOWING AND LONG-TERM STORAGE

TOWING

Failure to follow these instructions exactly can cause hitch ball failure or loss of trailer attachment resulting in a vehicle crash and/or personal injury.

Use the hitch ball only for towing trailers or vehicles connected to the ball with a socket-type coupler. The ball diameter must match the coupler socket size. Do not exceed the gross trailer weight shown on the ball.

Improper tightening can cause hitch ball failure or loss of trailer attachment.

- The threaded shank must protrude beyond the bottom of nut when tightened. If it does not, the ball shank is too short for the application and loss of attachment may occur.
- Check the nut tightness every time you hook up the trailer and at the beginning of each towing day. Tow only if the nut is tightened as specified.
- Replace any damaged or worn parts (except finish).
- Never attach a tow rope, chain, or stretch type elastic rope to the hitch ball.
- Do not fasten the trailer safety chain or any other type of attachment to or with, the ball.
- Lubricate the ball and coupler to minimize wear and friction. The coupler must not bind on the ball.

This product complies with V.E.S.C. Regulation V-5, C.S.A. Standard D-264 and the Safety Specifications and Requirements for Connection Devices and Towing Systems.

TRAILER MOUNT LONG-TERM STORAGE

When the sign is to be stored for extended periods of time, it is recommended to store the unit outdoors and in a sunny area to allow the unit to maintain the charge on the batteries. If it is to be stored indoors, keep the unit plugged into the AC charger when possible. When the sign is to begin operation again, a thorough inspection of all systems is advised before the sign is towed to the job site. Check the battery state of charge to confirm over 12 volts.

VEHICLE MOUNT LONG-TERM STORAGE

When the sign is to be stored for extended periods of time, the POWER switch should be turned OFF. When the sign is to begin operation again, a thorough inspection of all systems is advised before the sign is into operation.



TRAILER SETUP

Caution: If there is any portion of this instruction guide that is not understood, contact your local dealer or manufacturer.

BEFORE BEGINNING TRAILER SETUP:

1. Check the charge on the controller/battery level.
2. Check all jacks to make sure they are properly attached.

TRAILER SETUP

1. Position the trailer in the desired location so that the unit is directed toward traffic.
2. Chock the trailer wheels and remove the trailer from the vehicle.
3. Use jacks to brace and level trailer.
4. Remove tongue from trailer (if desired).

ELEVATING SIGN

1. Verify that the display is in the proper position and that the entire unit is level.
2. Clear all unnecessary personnel from the sign area to ensure safety.
3. Unlock the hand brake before attempting to RAISE/LOWER the mast to prevent damage.
4. Locate the toggle switch marked RAISE/LOWER on the controller located on the outside of the battery box. The switch is protected by a clear plastic cover.
5. Hold the switch in the "RAISE" position until the mast raises 10-12" to check for proper alignment with traffic.
6. If not properly aligned, release the hand brake and turn the sign toward traffic. Lock hand brake in the desired direction.
7. Finish raising the display to desired height.
8. Insert the locking pin into the hole in the inner mast shaft. *(CAUTION: The locking pin can only be inserted if the mast is at its maximum height).*



Raise/Lower Switch located on the side of the battery box.



Hand Brake



Remove the Locking Pin before lowering.

LOWERING SIGN *(CAUTION: The display can stick when elevated on new units. Gently move the display back and forth to loosen).*

1. Verify that the unit is level.
2. Clear all unnecessary personnel from sign area to ensure safety.
3. Remove the Locking Pin from the inner mast shaft.
4. Hold the switch in the "DOWN" position until the unit is approximately 10-12" from the docking station.
5. Unlock the hand brake and turn to align with the docking station.
6. Lower the display completely into docking station.
7. Lock the hand brake.



PROGRAMMING INTRODUCTION

MESSAGE DISPLAY CAPABILITIES

Your Message Sign provides messaging functionality to display predefined and custom messages in alphanumeric text. Full Matrix Message Signs can also display MUTCD graphics and animations. To catch motorists' attention we include an option to make the message flash. Programming can be accomplished with an on-board keyboard, a on-board Bluetooth tablet, or wirelessly with an internet connected device. On-board devices are conveniently located in the locking, weather-tight control cabinet on the backside of the sign.

TERMINOLOGY

CHANGEABLE MESSAGE

A Changeable Message is one that you create for your specific need. These messages can be input and saved for a later time or displayed immediately. You can edit changeable messages or delete them. K&K Message Signs allow for 2, 3, and 4 lines of text with varying number of characters per line depending on the font style. (See page 16 for font styles.) Follow the steps on page 15 of this manual to create or edit a Changeable Message.

PERMANENT MESSAGE

Permanent Messages are predefined into your system. A full list of text messages, graphics, and animated graphics is located on pages 21-27 of this manual. Simply type the number directly relating to the text or graphic message you want to display and activate. Permanent Messages cannot be modified or deleted. Follow the steps on page 11 to display a Permanent Message.

MESSAGE SEQUENCE

A Message Sequence is a message that spans multiple pages that are seen sequentially. A Sequence can be created from Changeable or Permanent Messages or a combination of the two. For example, page 1 might display "LEFT LANE CLOSED." Page 2 might then display "MERGE RIGHT." Use the steps on pages 18-19 of this manual to create and save the Message Sequences that you most commonly use.

QUICK SELECTION THUMB WHEEL

The **Quick Selection Thumb Wheel** located on the top left corner of the on-board controller keyboard allows access to the 16 most used messages without having to login. Create your list using the steps to Create/Edit a Changeable Message and assign a number 1-16. Automatically display the desired message by rolling the Thumb Wheel to that number. Record your Quick Message list on page 64 of this manual for reference.



Quick Selection Thumb Wheel for Trailer Mount Keyboard Models



Quick Selection Thumb Wheel for Vehicle Models



KEYBOARD PROGRAMMING

Tips

- * Use the PgUp and PgDn keys to adjust the contrast of the LCD Screen.
- * Press the ESC key at any time to go back.
- * Permanent Messages cannot be deleted or modified.
- * There is a list of Permanent Messages starting on page 15 of this manual.
- * Graphics are only for Full Matrix Message signs.

CREATE A CHANGEABLE MESSAGE

To enter and display a custom message follow the steps below.



- 1) Login:** Enter username: KAK
**NOTE: username is case sensitive - use ALL CAPS*
Press Enter
Enter Password: 123
Press Enter

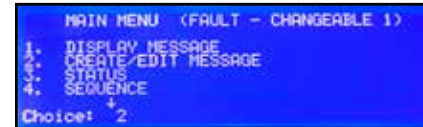

- 2) Press #2 (CREATE/EDIT MESSAGE)**
Press Enter



- 3) Enter the next available number (1-99)** *One not already assigned to a message on the list of changeable messages*
Press Enter



- 4) Enter your message** *Example:*
 1. Type "ROAD" **Press Enter**
 2. Type "WORK" **Press Enter**
 3. Type "AHEAD"

**REMEMBER: Each line can only contain 8 characters, including spaces and punctuation.* Press Enter to move the next line*



- 5) Press F9 (ACTIVATE)** when finished creating your message.
** NOTE: This will SAVE and DISPLAY your message. If you do not want to display the message immediately, Press F8 to SAVE only.*

- 6) Record your message** on the corresponding line in the log on page 22 for later reference.

SELECTING FONT STYLES

Press the F1 through F4 to select the font to display before inputting your Changeable Message.

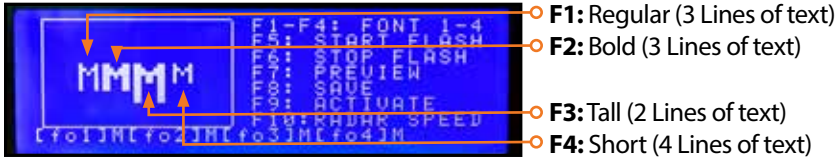

Regular Font Style

Bold Font Style



F3: Tall Font Style



F4: Short Font Style

MAKE THE MESSAGE FLASH

To conserve energy and draw drivers' attention to the message sign.

**NOTE: Only Changeable Messages can flash*



1) Press F5 (START FLASH).



2) Enter your Changeable Message

3) Press F6 (STOP FLASH).

4) Press F9 (ACTIVATE)

DISPLAY A PERMANENT MESSAGE

Permanent Messages are predefined messages already in the system. Reference the Permanent Message Text and Graphic list on pages 21-27.



1) Login: Enter username: KAK

**NOTE: username is case sensitive - use ALL CAPS*

Press Enter
Enter Password: 123
Press Enter



2) Press #1 (DISPLAY MESSAGE)
Press Enter



3) Press #1 (MESSAGE TYPE)
Press Enter



4) Press #1 (PERMANENT)
for messages preloaded on system
Press Enter



5) Press #2 (MESSAGE NUMBER)
Press Enter



6) Enter the MESSAGE NUMBER
from the list on pages 15-21
Press Enter

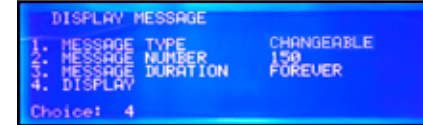

7) Press #4 (DISPLAY)
Press Enter

CREATE/EDIT A CHANGEABLE MULTI-PAGE MESSAGE SEQUENCE

The following steps will show you how to create a message that spans 2 or more pages, assign a number 1-99 to it, and save it to the Quick Selection Thumb Wheel.

EXAMPLE:



- 1) **Login:** Enter username: KAK
Press Enter
Enter Password: 123
Press Enter
- 2) **Press #2 (CREATE/EDIT MESSAGE)**
Press Enter
- 3) **Enter the Message Number** to edit or a new number for a new message
Press Enter
- 4) **Enter the 1st Message** to display
Press Enter
- 5) **Enter the 2nd Message** to display
Press Enter to add another page.
- 6) **Press F9 (ACTIVATE)** when finished
**NOTE: This will SAVE and DISPLAY your message. If you do not want to display the message immediately, Press F8 to SAVE only.*

Tip

* Use the Up and Down buttons to scroll through the Main Menu options.

CREATE A MESSAGE SEQUENCE/ MULTI-PAGE MESSAGE WITH PERMANENT AND CHANGEABLE MESSAGES

EXAMPLE:

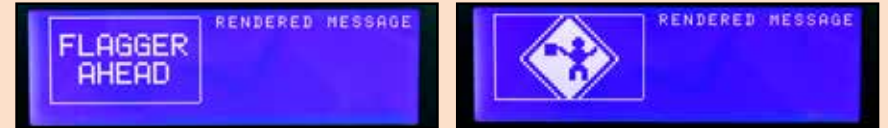

- 1) **Login:** Enter username: KAK
Press Enter
Enter Password: 123
Press Enter

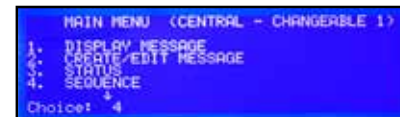

- 2) **Press #4 (SEQUENCE)**
Press Enter



- 3) **Enter the next available 1-99 number** on the list of changeable messages
Press Enter
Press ESC



- 4) **Press #2 (ADD MESSAGE TO SEQUENCE)**
Press Enter

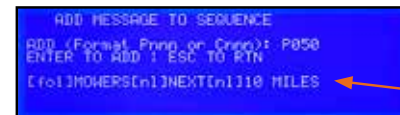

- 5) **Enter the message number** you wish to display. ***You must enter P (Permanent) or C (Changeable) message and a 3 digit number. (Ex: P050 = Permanent Message #50)*
Press Enter
Repeat to enter another message
Press ESC

*** Once you press Enter, the message you entered will show here.*

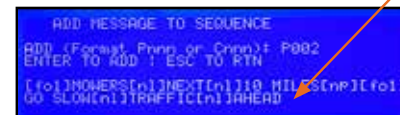

- 6) **SAVE AND ACTIVATE** saves your message sequence to the number you chose in step 2 and then activates the message.
Press #4 (SAVE AND CLOSE)
Press #5 (SAVE AND DISPLAY)

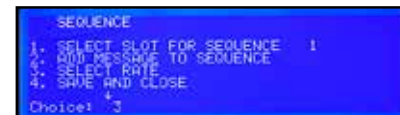

Tip

* Once you create your Message Sequence, you will save it as a changeable message.

CHECK MESSAGE SIGN STATUS

This menu selection lets you view the system status of current message, sign temperature, battery, and software version. These cannot be edited from this menu.

1. CURRENT MESSAGE	Displays current message that is active on the MB
2. SIGN TEMPERATURE	NA
3. POWER VOLTAGE SUPPLY	NA
4. BRIGHTNESS LEVELS	Photocell level (ambient lighting level 0-15) Brightness level (current LED brightness 0-15) Brightness mode (manual or photocell controlled)
5. CABINET DOOR STATUS	NA
6. SOFTWARE VERSIONS	Displays current firmware revisions of the Main and Menu processor codes.
7. LOCATION	NA

CONFIGURATION *System configuration settings*

1. GET DEVICE ADDRESS	Display the address of the sign
2. DATE AND TIME	Get the current date and time of the Message Sign Set the date and time
3. SET LCD CONTRAST	Modify the contrast level of the LCD screen
4. SET BRIGHTNESS MODE	Specify LED brightness to be determined by the PHOTOCCELL (automatically) or MANUALLY SET
5. SET MANUAL BRIGHTNESS	SET ONLY WHEN BRIGHTNESS MODE IS SET TO MANUAL. Specify the sign brightness.
6. SET RADAR MESSAGE <i>(if applicable)</i>	Select the message to be activated when the radar speed threshold is reached or exceeded.
7. SET RADAR SPEED <i>(if applicable)</i>	Specify the speed threshold (MPH) above which the RADAR MESSAGE is to be displayed.
8. SET DROP OUT VOLTAGE	NA
9. SET USERNAME AND PASSWORD	Add/Change the user ID and password to log in.
10. WEATHER MESSAGES <i>(if applicable)</i>	NA

SCHEDULE *Schedule message activations*

1. SCHEDULE NUMBER	Specify the desired schedule number to create or edit(1-12)
2. SCHEDULE TIME	Specify the activation time of day
3. SCHEDULE DAY/DATE	Specify the day and/or date of activation
4. SCHEDULE MESSAGE	Specify the message (permanent, changeable, or blank) to be scheduled.
5. ACTIVATE SCHEDULE	Activates the scheduling feature. This mode of operation will remain activated until either a new ACTIVATE SCHEDULE is performed, or a DISPLAY MESSAGE command is selected.

PERMANENT MESSAGE LIST: TEXT

1. 1 HOUR DELAY
2. 15 MINUTE DELAY
3. 30 MINUTE DELAY
4. ACCIDENT AHEAD
5. ACCIDENT CENTER LANE
6. ACCIDENT ON LEFT
7. ACCIDENT ON RIGHT
8. AMBER ALERT MISSING CHILD
9. BE PREPARED TO STOP
10. BRIDGE CLOSED AHEAD
11. BRIDGE WORK AHEAD
12. CALL 911
13. CAUTION ACCIDENT AHEAD
14. CAUTION BUMP AHEAD
15. CAUTION DETOUR AHEAD
16. CAUTION DIP AHEAD
17. CAUTION FLAGGER AHEAD
18. CAUTION FLOODED ROAD
19. CAUTION ICE ON ROAD
20. CAUTION ICE ON BRIDGE
21. CAUTION LOOSE GRAVEL
22. CAUTION MERGE AHEAD
23. CAUTION ROUGH ROAD
24. CAUTION SHOULDER DROP OFF
25. CAUTION SLOW TRAFFIC
26. CAUTION SOFT SHOULDER
27. CAUTION TRUCKS CROSSING
28. CAUTION TWO WAY TRAFFIC
29. CAUTION VEHICLES CROSSING
30. CAUTION WRECK AHEAD
31. CENTER LANE CLOSED
32. CURVE AHEAD
33. DENSE FOG AHEAD
34. DO NOT PASS
35. EXIT CLOSED AHEAD
36. EXIT HERE <---
37. EXIT HERE --->
38. EXPECT DELAY
39. FORM ONE LINE LEFT
40. FORM ONE LINE RIGHT
41. FORM TWO LINES LEFT
42. FORM TWO LINES RIGHT
43. FRESH TAR
44. GO SLOW ACCIDENT AHEAD
45. GO SLOW DETOUR AHEAD
46. GO SLOW FLAGGER AHEAD
47. GO SLOW MOVING VEHICLE
48. GO SLOW ROAD FLOODED
49. GO SLOW STOP AHEAD
50. GO SLOW TRAFFIC AHEAD
51. GO SLOW YIELD AHEAD
52. HEAVY TRAFFIC AHEAD
53. ICE ON ROAD
54. KEEP <--- LEFT
55. KEEP ---> RIGHT
56. KEEP LEFT
57. KEEP LEFT <---
58. KEEP RIGHT
59. KEEP RIGHT --->
60. LANE CONTROL AHEAD
61. LANE ENDS AHEAD
62. LANE NARROWS AHEAD
63. LANES SHIFT AHEAD
64. LEFT TWO LANES CLOSED
65. LEFT LANE CLOSED
66. LEFT LANE NARROWS
67. LIMITED SIGHT DISTANCE
68. LOOSE GRAVEL AHEAD
69. LOW BRIDGE AHEAD
70. MAX SPEED 25 MPH
71. MAX SPEED 30 MPH
72. MAX SPEED 35 MPH
73. MAX SPEED 40 MPH
74. MAX SPEED 45 MPH
75. MAX SPEED 50 MPH
76. MAX SPEED 55 MPH
77. MAXIMUM SPEED 30 MPH
78. MAXIMUM SPEED 10 MPH
79. MAXIMUM SPEED 20 MPH
80. MAXIMUM SPEED 30 MPH
81. MAXIMUM SPEED 40 MPH
82. M'CYCLES USE CAUTION
83. MEDIAN WORK AHEAD
84. MEN WORKING AHEAD
85. MERGE <--- LEFT
86. MERGE ---> RIGHT
87. MERGE AHEAD
88. MERGE LEFT
89. MERGE LEFT <---
90. MERGE RIGHT
91. MERGE RIGHT --->
92. MERGING TRAFFIC AHEAD
93. METAL PLATES AHEAD
94. MINIMUM SPEED 20 MPH



PERMANENT MESSAGE LIST: TEXT

- 95. MINIMUM SPEED 25 MPH
- 96. MINIMUM SPEED 30 MPH
- 97. MINIMUM SPEED 35 MPH
- 98. MINIMUM SPEED 40 MPH
- 99. MOWERS AHEAD
- 100. MOWERS NEXT 10 MILES
- 101. MOWERS NEXT 5 MILES
- 102. NEXT 10 MILES
- 103. NEXT 2 MILES
- 104. NEXT 3 MILES
- 105. NEXT 4 MILES
- 106. NEXT 5 MILES
- 107. NEXT 6 MILES
- 108. NEXT 7 MILES
- 109. NEXT 8 MILES
- 110. NEXT 9 MILES
- 111. NEXT MILE
- 112. NIGHT WORK AHEAD
- 113. NO PASSING
- 114. NO SHOULDER
- 115. OIL ON ROAD
- 116. ONE LANE BRIDGE AHEAD
- 117. ONE LANE TRAFFIC
- 118. PAINT CREW AHEAD
- 119. PASS LEFT
- 120. PASS RIGHT
- 121. PAVEMENT ENDS
- 122. PILOT CAR AHEAD
- 123. PREPARE TO MERGE
- 124. PREPARE TO STOP
- 125. RAMP CLOSED
- 126. RAMP CLOSED AHEAD
- 127. REDUCE SPEED
- 128. REDUCE SPEED 15 MPH
- 129. REDUCE SPEED 20 MPH
- 130. REDUCE SPEED 25 MPH
- 131. REDUCE SPEED 30 MPH
- 132. REDUCE SPEED 35 MPH
- 133. REDUCE SPEED 40 MPH
- 134. REDUCE SPEED 45 MPH
- 135. REDUCE SPEED 50 MPH
- 136. RIGHT 2 LANES CLOSED
- 137. RIGHT LANE CLOSED
- 138. RIGHT LANE NARROWS
- 139. ROAD CLOSE 1/2 MILE
- 140. ROAD CLOSED
- 141. ROAD CLOSED 1 MILE
- 142. ROAD CLOSED 1/4 MILE
- 143. ROAD CLOSED 3/4 MILE
- 144. ROAD CLOSED AHEAD
- 145. ROAD MACHINES AHEAD
- 146. ROAD NARROWS AHEAD
- 147. ROAD PAVING AHEAD
- 148. ROAD WORK
- 149. ROAD WORK 1 MILE
- 150. ROAD WORK 1/2 MILE
- 151. ROAD WORK 1000 FT
- 152. ROAD WORK 1500 FT
- 153. ROAD WORK 2 MILES
- 154. ROAD WORK 500 FT
- 155. ROAD WORK AHEAD
- 156. ROAD WORK NEXT 10M
- 157. ROAD WORK NEXT 1MI
- 158. ROAD WORK NEXT 2MI
- 159. ROAD WORK NEXT 3MI
- 160. ROAD WORK NEXT 4MI
- 161. ROAD WORK NEXT 5MI
- 162. ROAD WORK NEXT 6MI
- 163. ROAD WORK NEXT 7MI
- 164. ROAD WORK NEXT 8MI
- 165. ROAD WORK NEXT 9MI
- 166. ROCKS ON ROAD AHEAD
- 167. ROUGH ROAD AHEAD
- 168. RUNAWAY TRUCK RAMP
- 169. SHARP CURVE AHEAD
- 170. SHOULDER DROP OFF
- 171. SHOULDER WORK AHEAD
- 172. SIGNAL AHEAD
- 173. SIGNAL NOT WORKING
- 174. SINGLE LANE AHEAD
- 175. SLOW ACCIDENT AHEAD
- 176. SLOW DETOUR AHEAD
- 177. SLOW FLAGGER AHEAD
- 178. SLOW MOVING VEHICLE
- 179. SLOW ROAD FLOODED
- 180. SLOW STOP AHEAD
- 181. SLOW TRAFFIC AHEAD
- 182. SLOW YIELD AHEAD
- 183. SNOW BLOWERS AHEAD
- 184. SPEED LIMIT ENFORCED
- 185. STAY IN LANE
- 186. STEEP GRADE
- 187. STOP AHEAD
- 188. SURVEY CREW AHEAD











PERMANENT MESSAGE LIST: TEXT

- 189. SWEEPER AHEAD
- 190. TRACTION DEVICES REQUIRED
- 191. TRAFFIC EXIT
- 192. TRAFFIC EXIT LEFT
- 193. TRAFFIC EXIT RIGHT
- 194. TRAFFIC MUST EXIT
- 195. TRAFFIC MUST STOP
- 196. TRUCK CROSSING
- 197. TRUCKS USE LFT LANE
- 198. TRUCKS USE LOW GEAR
- 199. TUNE TO LOCAL RADIO
- 200. TUNNEL CLOSED AHEAD
- 201. TWO LANE TRAFFIC AHEAD
- 202. TWO WAY TRAFFIC AHEAD
- 203. UNEVEN PAVEMENT AHEAD
- 204. UNMARKED LANES AHEAD
- 205. USE CAUTION
- 206. USE DETOUR ROUTE
- 207. USE LEFT LANE
- 208. USE NEXT EXIT
- 209. USE RIGHT LANE
- 210. WATCH FOR TRUCKS
- 211. WATER ON ROAD
- 212. WEIGHT LIMIT AHEAD
- 213. WET PAINT
- 214. WORKERS IN TUNNEL
- 215. YIELD AHEAD

PERMANENT GRAPHICS

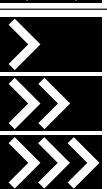
Arrow graphics number are for both Full Matrix and 2-Line message signs. When entering the graphic code, the brackets must be included (example: [g1]).





















Graphic	Description	TW	2-Line		3-Line	
	Arrow Right	#9	216	G1	256	G61
	Arrow Left	A	217	G2	257	G62
	Both Arrows	B	218	G3	258	G63
	Corners	C	219	G4	259	G64
	Straight Bar	D	220	G5	263	
	Double Diamonds	E	221	G6	262	
	Right Chevron	F	222	G7	260: [pt10o0] [g65] [np][g66] [np][g67] [np]	
	Left Chevron	0	223	G8	261: [pt10o0] [g65] [np][g69] [np][g70] [np]	

ARROW GRAPHICS THUMB WHEEL LIST

Arrow graphics are preset on the controller TW (Thumb Wheel) from the factory. Simply roll the TW to the letter or number associated with the desired graphic for easy selection.





















FULL MATRIX PERMANENT GRAPHICS

This list is applies to 3-Line (Full Matrix) Message Signs only. Permanent message number can be either of the two listed numbers. When entering the graphic code, the brackets must be included (example: [g1]).

Graphic	Description	Static Graphic		Animated Series
	Right Turn	216	G1	
	Left Turn	217	G2	
	Right Curve	218	G3	
	Left Curve	219	G4	
	Right "S" Bend	220	G5	
	Left "S" Bend	221	G6	
	Lane Shift Right	222	G7	
	Lane Shift Left	223	G8	
	Curves Ahead	224	G10	
	Crossroad	225	G11	
	Road Right	226	G13	
	Road Left	227	G14	
	Right Exit	228	G15	
	"T" Junction	229	G16	
	Fork	230	G17	
	Left Merge	231	G18	
	Right Merge	232	G19	
	Road Narrows	233	G20	
	Narrow Bridge	234	G22	
	Divided Road Ahead	235	G23	





FULL MATRIX PERMANENT GRAPHICS

This list applies to 3-Line (Full Matrix) Message Signs only.

Graphic	Description	Static Graphic		Animated Series
	Divided Road Ends	236	G24	
	Two Way Road	237	G25	
	Steep Grade	238	G26	
 	Slippery When Wet	239		[pt800][g28] [np][g29][np] [pt1600]SLIPPERY [n]WHENWET
	Uneven Pavement	240	G30	
	Two Lane Shift Right	241	G31	
	Two Lane Shift Left	242	G32	
  	Flagger Ahead	243		
	Manual Stop	244	G38	
  	Workers Ahead	245		[pt400][g35] [np][g36][np][g37] [np][pt1500] FLAGGER[n]AHEAD
	Railroad	246	G42	
	Cycles	247	G49	
	Pedestrians	248	G50	
	Deer	249	G51	
	Cattle	250	G52	
	Tractor	251	G53	

FULL MATRIX PERMANENT GRAPHICS

This list applies to 3-Line (Full Matrix) Message Signs only.

Graphic	Description	Static Graphic		Animated Series
	Horses	252	G55	
	Disabled	253	G57	
	Detour Right	254	G59	
	Detour Left	255	G60	



WIRELESS PROGRAMMING

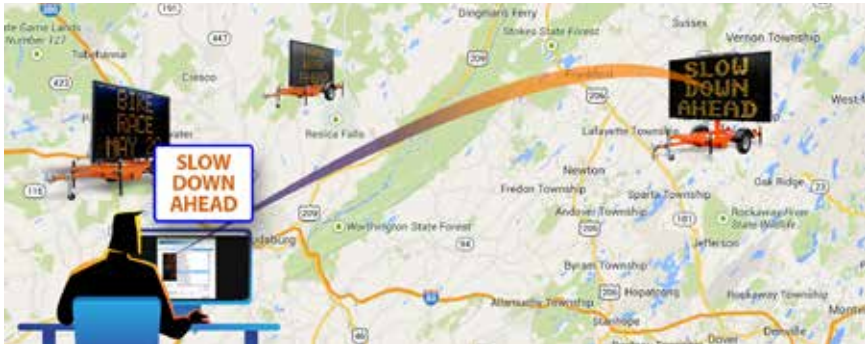

The Wireless Message Sign has messaging functionality from virtually anywhere using K&K Systems' proprietary communication system, the CrossTalk® Message Controller. Using the CrossTalk user-friendly web-based software you can program three lines of 18" high alphanumeric text. Choose from predefined messages or create a custom message to display on this all LED sign. Full matrix models capable of displaying graphics and animated graphics.

CROSSTALK® CONTROLLER

The CrossTalk is an Advanced, Solar-Powered Lighting Controller. On-board cellular technology provides a secure cloud server connection offering real-time access from almost anywhere. Designed for multiple applications, CrossTalk controllers are used for a variety of traffic & safety applications including school zone safety systems, bridge navigation beacons, cross-walk/pedestrian systems, speed/radar systems and more. Utilizing solar power and both cellular and short-range wireless connectivity, CrossTalk applications can be setup quickly and provide more functionality and flexibility than traditional "wired" systems. A single CrossTalk can control multiple nodes across an entire campus and provide web connectivity for schedules, status monitoring, diagnostics, and real-time control.

The CrossTalk device is a rugged, integrated unit which provides a built-in solar controller with Maximum Power-Point Tracking (MPPT), battery management with low-voltage disconnect (LVD), on-board cellular connectivity (3G / 4G), short-range wireless (900MHz), multi-function programmable lighting control, support for up to (4) beacons, auto-dimming, and a scheduler all in one compact enclosure. Our Wireless Message Signs can be accessed and configured with any internet connected device using K&K Systems' CrossTalk web-based cloud interface.



DESCRIPTION OF CROSSTALK CONTROLS

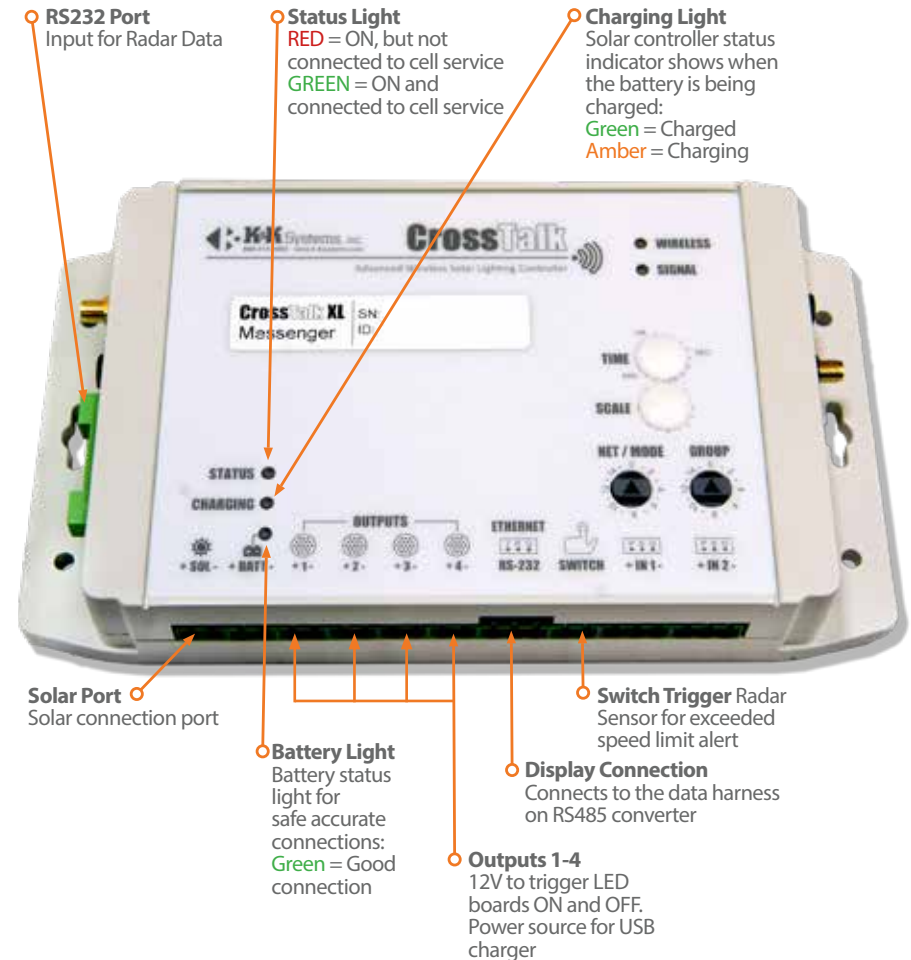



CROSSTALK ONLINE SOFTWARE WIRELESS CONNECTION

Your **Cross Talk Account** is setup and ready to use upon arrival of your unit. To start using the CrossTalk online options, access the login page located at:
<http://www.kkCrossTalk.com/>



In the main menu of the website you will see six quick link tabs including the login tab on the right side. These tabs have detailed information on how the CrossTalk operates and how it communicates through both internet (long range) and radio (short range).

Upon accessing the login tab, you will be taken to a new screen that prompts you to enter a username and password that is provided by K&K Systems. Below is the link to quickly access the login screen without going through the homepage.

<http://www.kkCrossTalk.com/XTLOGIN.php>



LOCATIONS

The **Locations** menu is the default page upon login. The available units are listed in the window.

NAME

The **Name** of each unit will be displayed in the first column. The default names can be changed at any time to specify units or to better locate them.

DESCRIPTION

In the **Description** column the information can be edited for details that will differentiate that device from others in the same area.

K&K uses the last 4 digits of the VIN number as the default upon delivery.

DEVICE ID/IP/PORT

The **Device ID/IP/Port** column displays the information used to communicate to the device via the online server. Although the information can be edited, it should **not** be changed unless needed for changing units or IP settings. Please contact of a K&K Systems Customer Representative to assist in the event changes need to be made.

STATUS ICON

The **Status** icon provides a quick link to see the condition of each unit's components functioning status. Click the icon to inspect Lights/Beacons, Battery Voltage, Solar Voltage, Date, Time, Current Message, Output 4, Status ON or OFF, and GPS coordinates.

COMMANDS & SETTINGS ICON

The **Commands & Settings** icon links to the unit's messaging controls. Enter Custom Messages, select Preset Messages, Edit Messages, or select Arrow Modes that will display on your Message Signs.





COMMANDER

MESSAGE EDITOR

Once logged in the **Commander** window will open a blank sign. Select the **Message Editor** tab to enter new messages, edit messages, or select a Preset Message. Send your message to units in your network.



DESCRIPTION OF MESSAGE EDITOR CONTROLS

Message Sign Unit Selection from the drop down menu.

Message Preview will display exactly as it is seen here.

Add Page

Delete Page

Preset Message Menu

Message Entry
Type new message in window. A maximum of 8 characters per line.

The box will flash red when number of characters per line is exceeded. Press ENTER to go to the next line.

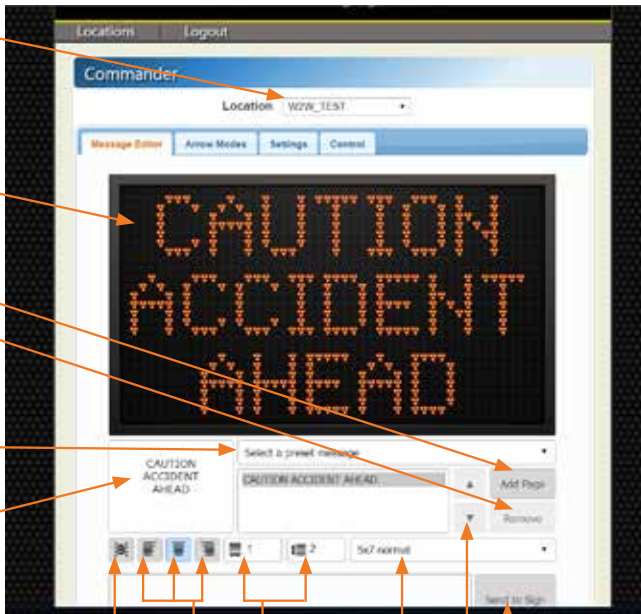

Select to make page flash. Must be selected on each page separately.

Text Justification
• Flush Left
• Centered
• Flush Right

Text Spacing
• Horizontal
• Vertical

Font Style/Size

Moves Page up and down in the sequence

Send Message to Sign for Display



PRESET MESSAGES

SELECTING MESSAGE

Locate the **Preset Message** drop down menu below the preview window. This window will display all of the available messages. Select the desired message. Preset Messages can be edited in the **Message Entry** window to customize for exact situation. (Example: Preset Message is "15 Minute Delay;" however, the delay is actually 20 minutes. Simply change the time in the Message Entry window by deleting "15" and replace with "20.")

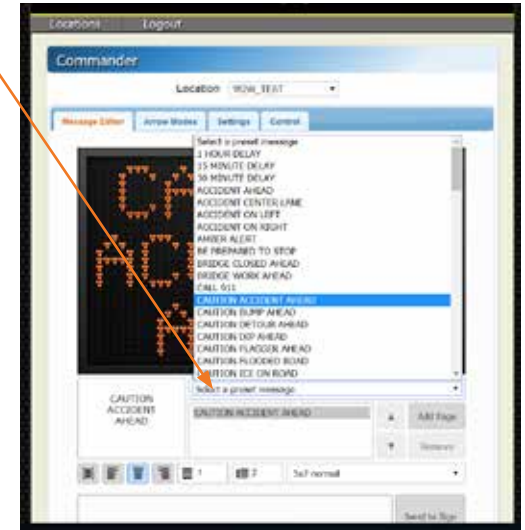

ADDING A PAGE

To display multiple pages on your message sign, simply click the "Add Page" button and select your message. The message will appear on the message sign exactly the way it looks in the preview window.

DELETING A PAGE

To delete a page from your message sign, select the page and then click the "Remove" button.

MAKING A PAGE BLINK

Click the blink button on the bottom of each page.

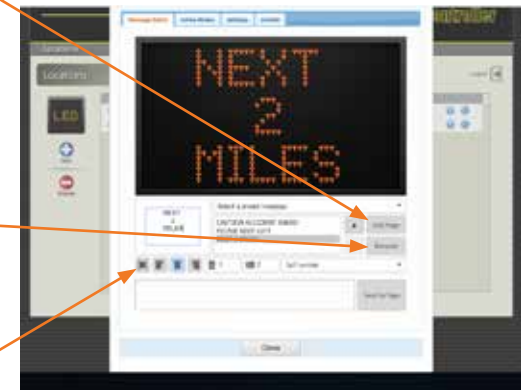



CUSTOM MESSAGES

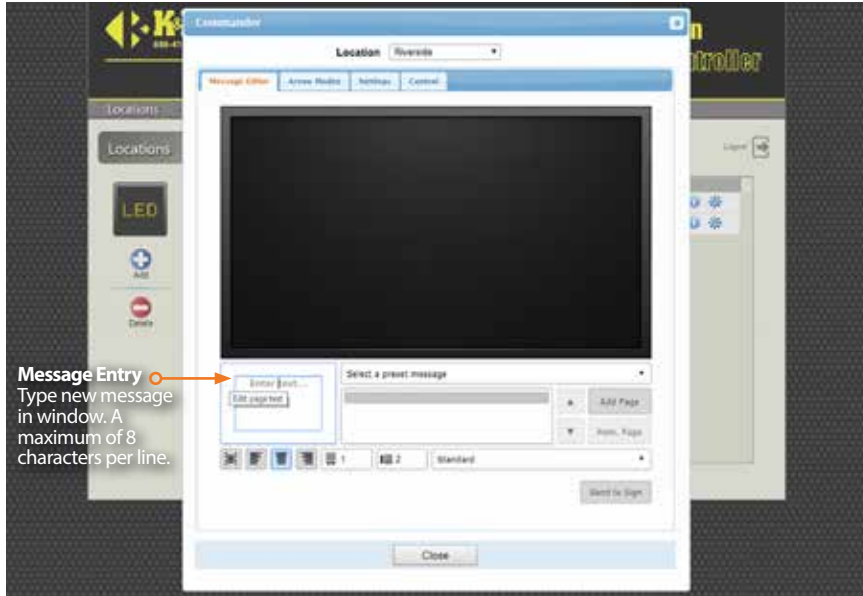

ENTERING A CUSTOM MESSAGE

Locate the **Message Entry** window below the preview window. Type your message. All caps and lowercase text can be used. Your message is automatically centered on the display. If the maximum number of characters (8) per line is exceeded the window will flash red. Press the ENTER key to go to the next line. Click the **Send to Sign** button when ready to display.



Message Entry window with number of characters exceeded.

FORMATTING TEXT

After entering your message, click the desired button make the text:

- Blink. *Selected on each page separately.*
- Flush left
- Centered
- Flush Right
- Letter Spacing Horizontally
- Text Line Vertical Spacing
- Text Size and Style

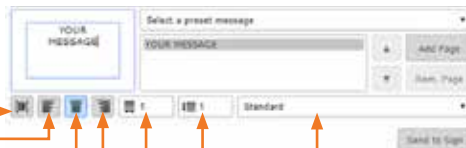

ARROW MODES

ARROW MODE SELECTION - ONLY FOR FULL MATRIX DISPLAYS

Under the **Arrow Modes** tab are the MUTCD approved arrow patterns. Each arrow diagram previews the series of configurations that animate the arrow. Select the desired arrow pattern by clicking the pencil  at the right of the diagram. The selection is confirmed in the window below the arrow diagrams. Click the **Close** button when finished.

- Arrow Pattern Preview
- Send Command
- Command Confirmation

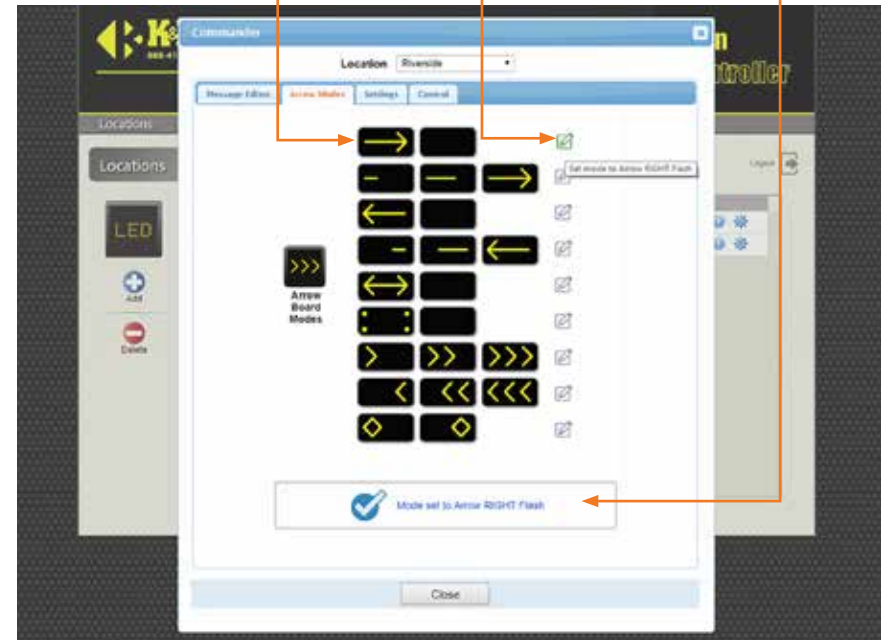



SETTINGS

Under the **Settings** tab are all of the controls for how your message displays on your message sign including message timing, flash rate, and dimming.

- **Write Button** - sends command to display
- **Message Timing** - the amount of time the page displays in a multiple page message
- **Flash Rate** - the amount of time the page flashes
- **Dimming** - amounts. Default setting are 1 and 200.
 - Minimum Amount
 - Maximum Amount
- **Radar** - Enable/Disable, message selection
- **Radar Time-out** - amount of time the message is displayed after it detects a vehicle. This is a safety measure so that a speeder will no interrupt the regular message.
- **Speed Limit** - Speed at which the message is displayed.
- **Log Setup** - Not used
- **Read** - checks current settings
- **Write** - sends all settings changes to message sign
- **Confirmation** - displays command when accepted



CONTROL

The **Control** tab provides access to message signs to confirm date and time settings, perform tests, and receive information including current working status and location.

- **Location** - select unit in drop down menu
- **Status** - provides information about unit current working stats and settings
- **Device Location** - displays unit location on a map with GPS coordinates
Map will not display unless Pop-Ups are enabled for this website.
- **Info** - displays firmware and unit ID
- **Pixel Test** - displays one character per message sign panel and lights all LED diodes. Used for troubleshooting.

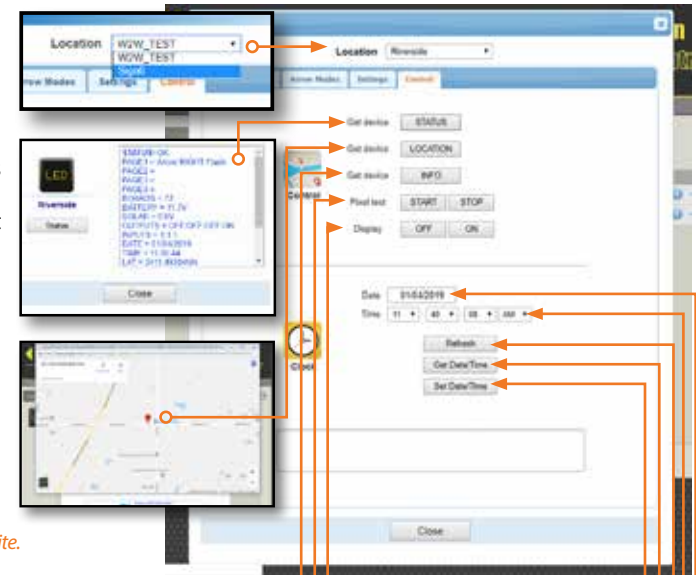

- **Set Date/Time** - sets the unit's date and time to above settings
- **Get Date/Time** - gets the unit's current date and time
- **Refresh** - inputs the computer's date and time into the CrossTalk settings above
- **Display** - turns display ON and OFF. Display automatically turns ON when message is sent to it. *Always turn OFF the display for storage.*
- **Time** - displays current time
- **Date** - displays month/day/year



BLUETOOTH PHONE & TABLET PROGRAMMING

Bluetooth controlled units are equipped with a handheld phone located inside the control box and can be upgraded to tablets. One of the advantages of Bluetooth is that it does not require cellular service to operate. K&K proprietary software called SignMaster allows you to create and send messages to your message sign. Your phone or tablet has SignMaster installed and ready to use upon delivery.



PHONE & TABLET OPERATION

To use the phone or tablet you must be within the range of the Bluetooth signal to connect and operate your unit.



Power on the Phone or Tablet
Press the power button located on the side of the phone or the tablet.

Navigate to the SignMaster App
Swipe up on the screen

SWIPE

Open SignMaster App
Tap on the SignMaster logo.

*If Bluetooth is turned off the message below will popup. Press **Allow** to continue.*



DESCRIPTION OF PHONE & TABLET CONTROLS



PHONE CONTROLS



TABLET CONTROLS



TABLET & PHONE PROGRAMMING

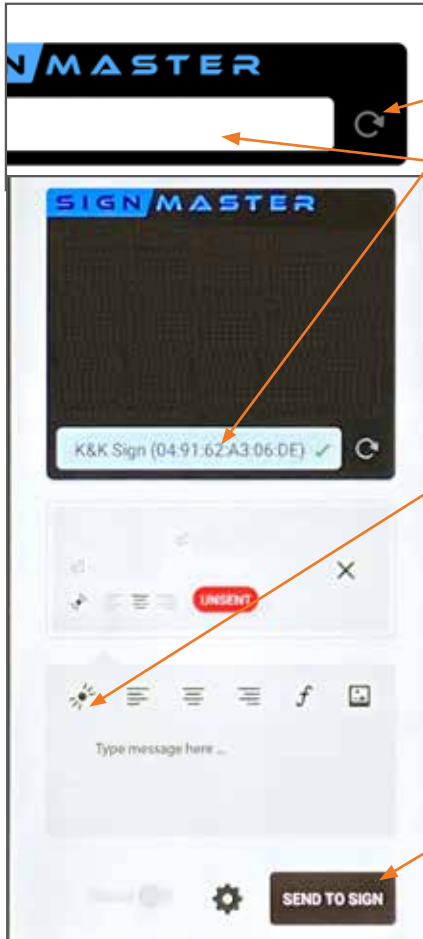

CONNECTING TO MESSAGE SIGN

Tap the **Refresh** button to activate the search for the message sign associated with this tablet. The **Unit ID** will appear in the box when connected. (To confirm Unit ID, see the ID label on the inside of the control cabinet door.) Before starting a new session, close the app if it has been running in the background and restart.

CREATE A MESSAGE

Once connected a blank preview screen will appear.

- 1) Tap the area that says: **Type message here...** The keyboard will popup.
- 2) Type your message with a maximum of **8 characters per line**. Tap the return key to go to the next line.
- 3) Press the **phone/tablet's** back button to remove the keyboard and to see the whole preview window.



- 4) Tap the **SEND TO SIGN** button to display when finished.

PHONE AND TABLET ALL CAPS



Tip: Hold for all caps on phone. Double Tap for all caps on tablet.



CREATE A SEQUENCE/MULTI-PAGE MESSAGE

SignMaster allows 4 pages of messages to be displayed in a sequence.

- 1) Tap **Type message here...**
By default the message will be applied to the First Page.
- 2) Type the first page message.
- 3) Tap on the second page space.
- 4) Type the second page message.
- 5) Repeat steps 3 and 4 for additional pages.
- 6) Scroll pages by swiping up or down.
- 7) Press the tablet's back button to remove the keyboard and to see the whole preview window.
- 8) Tap the **SEND TO SIGN** button to display when finished.



USING GRAPHICS

Choose the page you wish to add a graphic to my tapping on the page. Tap the picture icon in the format menu. Choose the graphic or animated graphic by tapping on it.



EDIT A MESSAGE

Edit a message by double tapping on the page you wish to change or by tapping the X on right side of the page. Use the keyboard to edit the text or graphic. Press the back button to preview changes.





FORMATTING TEXT

SignMaster let's you format text using the menu above the message input field.

After entering your message, tap the desired button to make the text:

- Make Message Flash
- Align Left
- Align Centered
- Align Right
- Text Size and Style

See options below

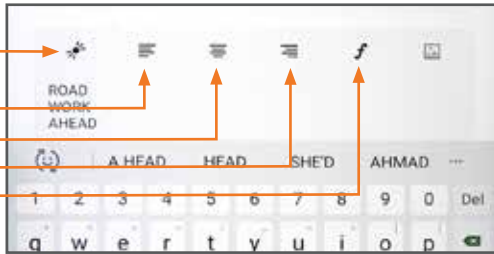

Alignment



Align Left

Align Centered

Align Right

Font Size and Styles



Short

Regular

Bold

Note: When using the **BOLD** option the number of characters is limited to 6 per line.

CLOSING SIGNMASTER

Press the phone/tablet's Page Button.

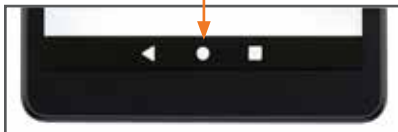

Swipe up







or tap the "Close All" button. the app.







PARTS LIST

PART NUMBER	DESCRIPTION
MESSAGE SIGNS	
SM-9001	MB14821 LED Panel
SM-9002	MB3L LED Panel
SM-9003	MB9757 LED Panel
SM-9005	MB8249 LED Panel
EC-1600	Controller/Motherboard unit. Standard keyboard equipped models only.
CC-SOLAR30	30A Solar Regulator standard trailer only
ELCD-LM6270SY	LCD screen for control box trailer and truck RMA
TH-TSR16D	Power Switch for control box.
EK-595MINISLIM	Mini keyboard for control box (black)
KK-PCELLM18	Message Board Photocell
ET-TWA	Thumb Wheel, message quick select rotary switch
BCH-12-60	110VAC on board battery charger
BAT-12-100A	100Ah Battery
TRUCK MOUNT	
SM-9003	VCMD1842190, VCMD1848190, VCMD2742190, VCMD2748190 LED Panel
SM-9005	VCMD1842158, VCMD1848158, VCMD2742158, VCMD2748158 LED panel.
VA-600B	12V Linear actuator for M-LP-A mount.
CYACT-001	Control board for actuator system
WIRELESS	
CROSSTALK-M-10B	Cellular 4G/LTE + Bluetooth + GPS message board controller. With a built in solar regulator.
ANTENNAKIT-4	Puck style antenna for Wireless CMS units. Cell and GPS functionality.

PROBLEM	STEP 1	STEP 2	STEP 3	STEP 4	STEP 5
Message Sign does not power on	<ul style="list-style-type: none"> Check for power at the plug, It should be at least 12V. The plug is located on bottom of the frame. 	<p>If no power:</p> <ul style="list-style-type: none"> Check for connection at the vehicle's battery. <p>If inline fuse was installed:</p> <ul style="list-style-type: none"> Check fuse 	<p>If power is present at plug:</p> <ul style="list-style-type: none"> Open the message sign. Refer to the wiring diagram and trace 12V from the power cord. <i>A 12V battery will have to be applied to actuators if in the lowered position.</i> 	<p>If controller will power up, but the message board does not:</p> <ul style="list-style-type: none"> Check the data cable for signs of damage. <p>If damaged or burned:</p> <ul style="list-style-type: none"> Replace cord. 	<p>If the problem persists:</p> <ul style="list-style-type: none"> Call K&K Systems for further Assistance.
Message Sign will not save messages	<ul style="list-style-type: none"> Open the controller 	<ul style="list-style-type: none"> Locate CR2032 battery on the motherboard. 	<ul style="list-style-type: none"> Check the battery for at least 3V. Optimal level is 3.2V 	<ul style="list-style-type: none"> Replace battery if below 3V. 	<ul style="list-style-type: none"> Battery replacement requires a reset. Custom messages will be lost. Input your custom messages again after replacement.
Message Sign too dim/bright	<ul style="list-style-type: none"> Locate photocell, bottom of the display case panel next to the power cord.  	<ul style="list-style-type: none"> Ensure the photocell is not covered by debris. 	<ul style="list-style-type: none"> Test photocell with a flashlight. Hold a flashlight at the photocell to see if it brightens up. If it wont dim, place a piece of electrical tape over the bulkhead to test if it dims. Brightness changes have a short delay 	<p>If dimming does not change:</p> <ul style="list-style-type: none"> Remove the bottom right LED panel. Trace wires from photocell back to motherboard. <i>Refer to included wiring diagram to verify wiring on page 52.</i> 	<p>If the photocell is not working:</p> <ul style="list-style-type: none"> Call K&K Systems for a replacement.
Message Sign will not raise or lower	<ul style="list-style-type: none"> Test for 12V at the power plug of the actuator motors. When the sign is supposed to raise the voltage is positive, when the sign is supposed to lower the voltage should go negative. 	<p>If there is no power or it is below 12V:</p> <ul style="list-style-type: none"> Trace power wires and look for loose connections inside the message board. 12V will need to be applied to the motors to raise them or, they will need to be dismantled to manually raise it. 	<p>The power wire leads to a small chip inside the board:</p> <ul style="list-style-type: none"> Check for a light to be on. Test for power at the ports. Main power in should be 12V. 	<p>If there is 12V at the chip or it is not on:</p> <ul style="list-style-type: none"> Call K&K Systems for further Assistance. 	
Dead Pixels	<p>Test boards for pixel outage:</p> <ul style="list-style-type: none"> Create a custom message. Type: <code>[cb9]</code> for the yellow page. <i>Include the brackets</i> Press the F9 key. 	<p>Once all the LEDs are activated:</p> <ul style="list-style-type: none"> Make a note of the boards that have dead pixels. 	<ul style="list-style-type: none"> <i>Do not leave on this page for extended periods of time. It will deplete the batteries quickly.</i> 	<ul style="list-style-type: none"> Contact K&K with outage information for repairs. 	

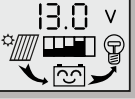
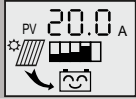

TRAILER MOUNT: KEYBOARD TROUBLESHOOTING GUIDE

Please call 888-414-3003 for Tech Support if this guide does not solve your issue.

PROBLEM	STEP 1	STEP 2	STEP 3	STEP 4	STEP 5
Message sign does not power on	<ul style="list-style-type: none"> Check for power at the plug, It should be at least 12V with a smiling battery. <i>The plug is located on bottom of the frame.</i> 	<p>If the voltage is below 12V:</p> <ul style="list-style-type: none"> Charge the unit via 110VAC charge for at least 24hrs. Please see the section below on the message board not charging via solar once charged. 	<p>If the regulator reports at least 12V:</p> <ul style="list-style-type: none"> Is the arrow from the smiling battery to the light bulb filled?  <p>If not filled:</p> <ul style="list-style-type: none"> Click the right yellow button (LOAD ON/OFF) until it's filled. 	<p>If the solar regulator reports good voltage, the LOAD ON/OFF function reports its outputting power to the unit but it's still not powering on:</p> <ul style="list-style-type: none"> Test for power at the power switch. 	<p>If the issue persists:</p> <ul style="list-style-type: none"> Call K&K Systems for further Assistance.
Message Sign will not save messages	<ul style="list-style-type: none"> Remove the bottom right LED board to expose the rear of the control box. 	<ul style="list-style-type: none"> Locate CR2032 battery on the motherboard. <i>See page 51 for detailed instructions for changing the battery.</i> 	<ul style="list-style-type: none"> Check battery for at least 3V. 	<ul style="list-style-type: none"> Replace battery if below 3V. Optimal level is 3.2V 	<p>Battery replacement requires a reset. Custom messages will be lost. Input your custom messages again after replacement.</p>
Message Sign too dim/bright	<ul style="list-style-type: none"> Locate photocell, bottom right of LED panel display. The second vertical support from the right.  	<ul style="list-style-type: none"> Ensure the photocell is not covered by debris. 	<ul style="list-style-type: none"> Test photocell with a flashlight. Hold a flashlight at the photocell to see if it brightens up. If it wont dim, place a piece of electrical tape over the bulkhead to test if it dims. Brightness changes have a short delay 	<p>If dimming does not change:</p> <ul style="list-style-type: none"> Remove the bottom right LED panel. Trace wires from photocell back to motherboard. <i>Refer to included wiring diagram to verify wiring on page 54.</i> 	<p>If the photocell is not working:</p> <ul style="list-style-type: none"> Call K&K Systems for further Assistance.
Message board not charging via solar once..	<ul style="list-style-type: none"> Check that the solar regulator registers a panel connected to it. The main screen should have a solar panel symbol with an arrow.  	<p>If the solar panel symbol is not present:</p> <ul style="list-style-type: none"> There is a connection issue. Check terminals at solar the regulator and at the solar panels. Check solar wires for continuity. 	<p>If the solar panel symbol is present:</p> <ul style="list-style-type: none"> Click the right button on the two times to bring up the solar generating current screen.  	<ul style="list-style-type: none"> Solar Generating current should display between 0.1A and 5A depending on sun conditions. If there is ample sunlight and your current is at 0.00, check the polarity of your solar cables. Pull the solar wires out and verify with a voltmeter. 	<ul style="list-style-type: none"> If polarity is correct, and the wiring is good. But still no current, please inspect panels for damage and call K&K Systems.
Dead Pixels	<p>Test boards for pixel outage:</p> <ul style="list-style-type: none"> Create a custom message. Type: [cb9] for the yellow page. <i>Include the brackets</i> Press the H9 key. 	<p>Once all the LEDs are activated:</p> <ul style="list-style-type: none"> Make a note of the boards that have dead pixels. 	<ul style="list-style-type: none"> <i>Do not leave on this page for extended periods of time. It will deplete the batteries quickly.</i> 	<ul style="list-style-type: none"> Contact K&K with outage information for repairs. 	
LED Panel displays incorrect letters	<ul style="list-style-type: none"> Locate the Dip Switch Diagram on page 59. 	<ul style="list-style-type: none"> Locate the panel that is displaying incorrectly. Verify your units model number, located on the bottom right of the VIN tag. <i>(Example MB3L, MB14281 etc...)</i> 	<ul style="list-style-type: none"> Turn OFF all dip switches. Reset switches per Dip Switch Diagram for your units model number. 	<p>If the LED board still displays incorrectly:</p> <ul style="list-style-type: none"> Call K&K Systems for further Assistance. 	

TRAILER MOUNT: WIRELESS TROUBLESHOOTING GUIDE

Please call 888-414-3003 for Tech Support if this guide does not solve your issue.

PROBLEM	STEP 1	STEP 2	STEP 3	STEP 4	STEP 5
I can't connect to my message sign on the website.	<ul style="list-style-type: none"> Attempt to get the status again. Occasionally the CrossTalk will not connect on the first attempt. 	<p>If no connection:</p> <ul style="list-style-type: none"> Go check the Crosstalk located in the control cabinet. Confirm the Status light is flashing and green. 	<p>If Status light is flashing red:</p> <ul style="list-style-type: none"> Check that the antenna for obstructions. Ensure antenna wires are tight and secured. 	<p>If antennas are on correctly:</p> <ul style="list-style-type: none"> Pull the solar power wires, and the battery wires. Wait 10 sec, and reinstall. Attempt to reconnect once the status light is flashing green. 	<p>If no change:</p> <ul style="list-style-type: none"> Call K&K Systems for further Assistance.
My display is not turning on.	<ul style="list-style-type: none"> Try connecting to the message sign via the website: www.kkcrosstalk.com 	<p>If you can connect, but it will not display:</p> <ul style="list-style-type: none"> Manually turn the display OFF and then ON under your Control tab 	<p>If no change:</p> <ul style="list-style-type: none"> Check the connection on Output 4 on the CrossTalk. Ensure a good connection. 12V must be present at Output 4 after a message is sent. 	<p>If no change:</p> <ul style="list-style-type: none"> Call K&K Systems for further Assistance. 	
My message sign stops working after a few days.	<p>Message sign may not be charging.</p> <ul style="list-style-type: none"> Charge via the 110VAC on board charger for 24hrs then test solar following the next steps: 	<ul style="list-style-type: none"> Check the solar voltage under the Status  button on the unit on the website. During the day the voltage should range between 15V to 21V. 	<p>If you have very low or no solar voltage:</p> <ul style="list-style-type: none"> Inspect your wires leading to the solar panels. Check for continuity between panels and solar plug. Unplug solar, check with a voltmeter, confirm voltage is present and positive, not negative. 	<ul style="list-style-type: none"> Check that the message sign is in full sun for the majority of the day. Check the batteries with a load tester to confirm they will hold a charge. 	<ul style="list-style-type: none"> Confirm that your dimming is set to the below. Incorrect dimming settings may cause premature battery draining. Dim Min: 1 Dim Max: 60 <p>If no change:</p> <ul style="list-style-type: none"> Call K&K Systems for further Assistance.
I can't see a map on my device location.	<ul style="list-style-type: none"> Check that the correct unit is selected Check if receiving the "Device GPS Information" message with a check mark when you hit Device Location 	<p>If yes:</p> <ul style="list-style-type: none"> Check the url address bar on your device to make sure you're not getting a Pop-Up Blocker notification.  	<p>If yes:</p> <ul style="list-style-type: none"> Click the Pop-Up Blocker icon  to change browser settings to allow Pop-Ups on this website 	<p>If no change:</p> <ul style="list-style-type: none"> Call K&K Systems for further Assistance. 	
LED Panel displays incorrect letters	<ul style="list-style-type: none"> Locate the Dip Switch Diagram on page 59. 	<ul style="list-style-type: none"> Locate the panel that is displaying incorrectly. Verify your units model number, located on the bottom right of the VIN tag. (Example MB3L, MB14281 etc...) 	<ul style="list-style-type: none"> Turn OFF all dip switches. Reset switches per Dip Switch Diagram for your units model number. 	<p>If the LED board still displays incorrectly:</p> <ul style="list-style-type: none"> Call K&K Systems for further Assistance. 	



CROSSTALK FUSE LOCATION & REPLACEMENT

Access the CrossTalk components by removing the CrossTalk from the control box.

- 1) Turn the CrossTalk over to remove 4 screws on the corners.
- 2) Loosen the screws until the face cover easily separates. The screws will remain in the housing.
- 3) Carefully lay the cover over as to not to break the connection of the aerial wire.
- 4) Locate the 10 amp Low Profile Mini Fuse at the bottom left of the control panel.
- 5) Remove the fuse by grasping with fingers and gently rocking the fuse side to side.
- 6) Inspect the fuse by looking through the translucent housing at flat wire in the center. If the wire is solid, the fuse is good. In a blown fuse, the wire will be broken.
- 7) Replace the blown fuse with a new one by inserting into the port and firmly pressing it into place.
- 8) Align the covers and tighten the screws until the cover is snug.
- 9) Remount the CrossTalk to control box.

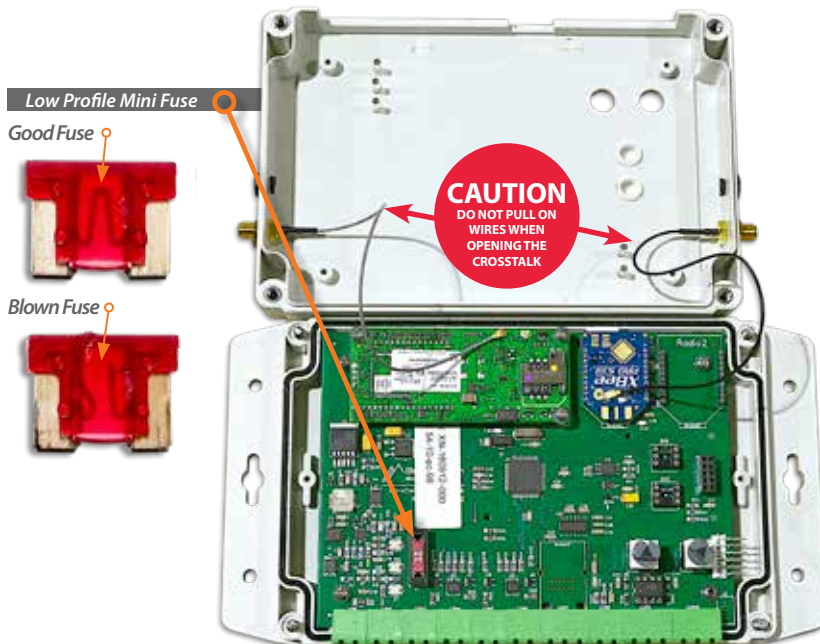

KEYBOARD BATTERY LOCATION & REPLACEMENT

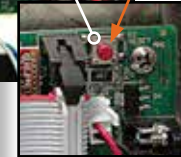
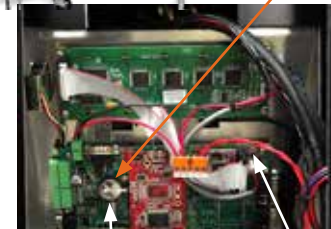

- 1) Remove the bottom right LED board to expose the rear of the control box.
- 2) Locate the CR2032 battery on the motherboard.
- 3) Use a flathead screwdriver to lift the battery.
- 4) Slide the battery to the side to remove.
- 5) Insert a new battery under the holding clip and slide it into place.
- 6) Press the reset button.



- 7) On the LCD screen in the control cabinet you will see the "Device Initializing" message. Once this process is complete the Login Page will open.
- 8) **Login:** Enter username: KAK
Press Enter
Enter Password: 123
Press Enter
- 9) **Press #5 (Configure)**
Press Enter
- 10) **Press #3 (LCD Contrast)**
Press Enter
- 11) **Press #1 (To Save the Contrast)**
Press Enter



VEHICLE MOUNT WIRING DIAGRAMS

CONTROLLER

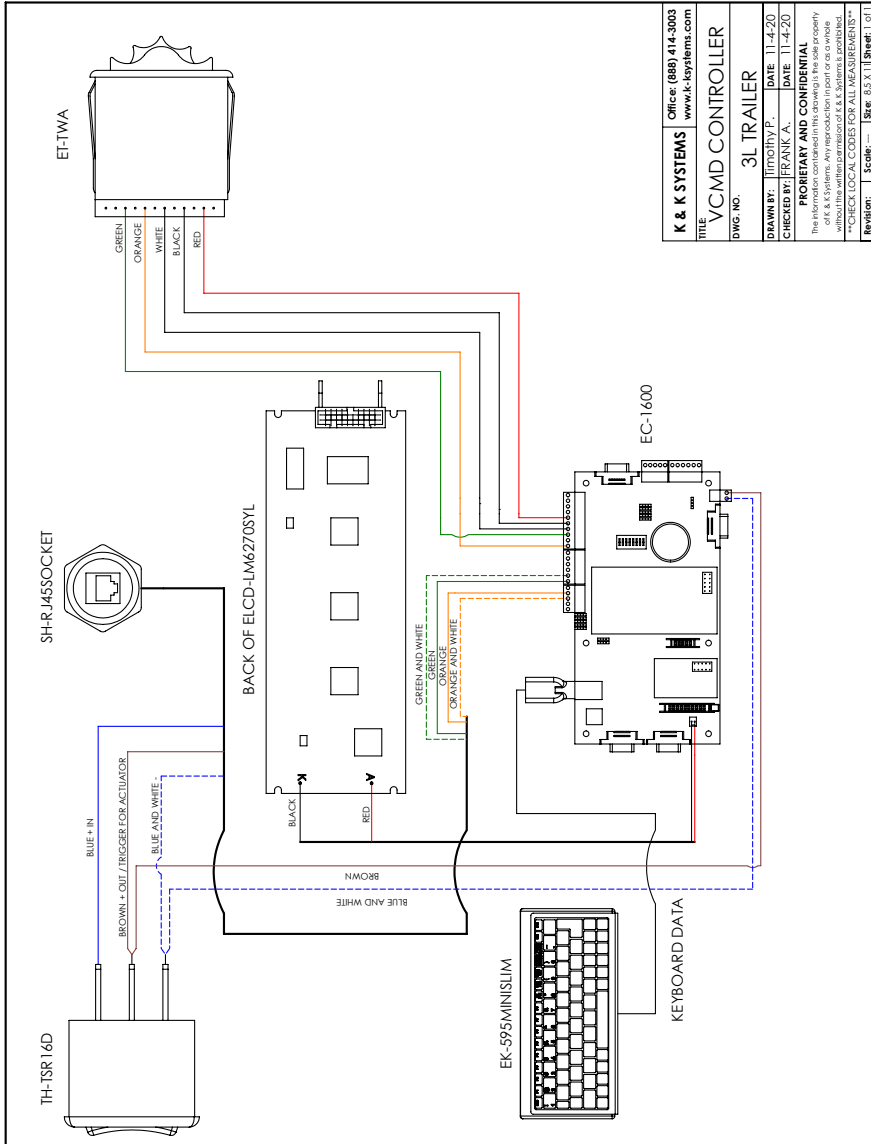

MESSAGE SIGN

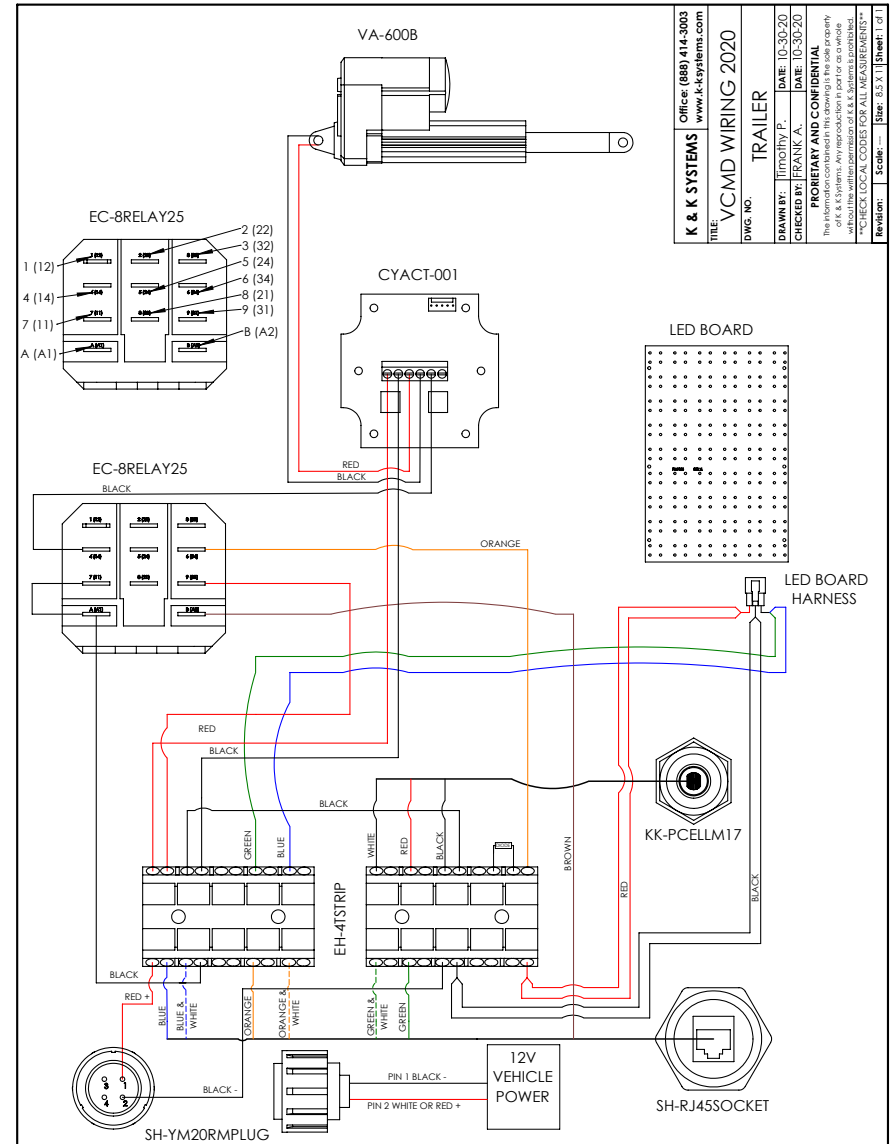



TRAILER MOUNT: KEYBOARD WIRING DIAGRAMS

CONTROLLER

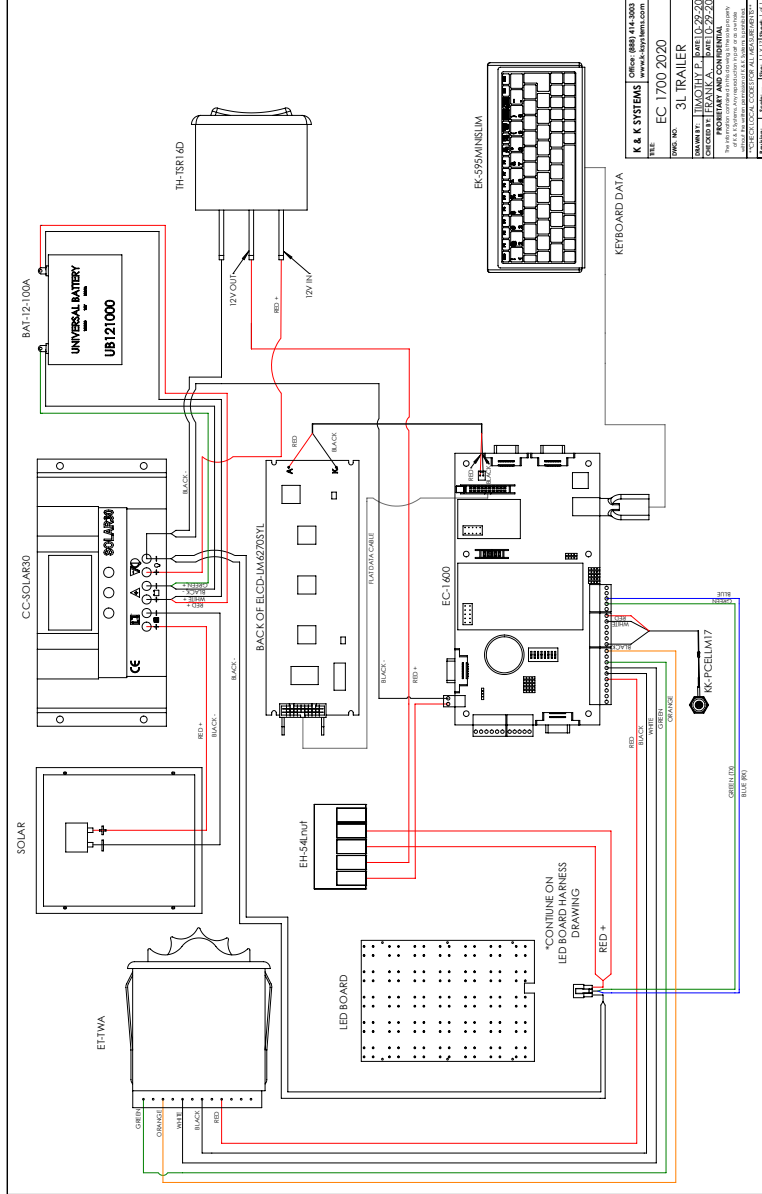

BATTERY BOX

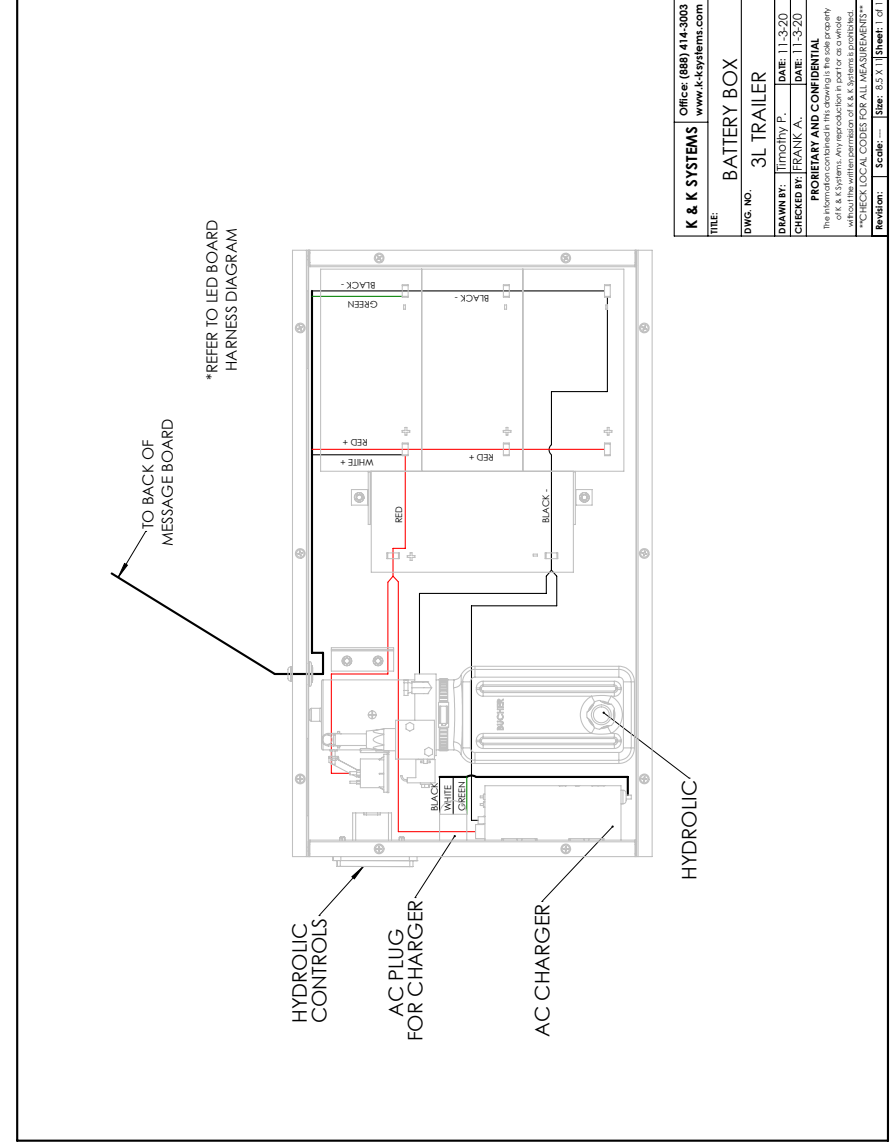



TRAILER MOUNT: WIRELESS WIRING DIAGRAMS

CROSSTALK XL

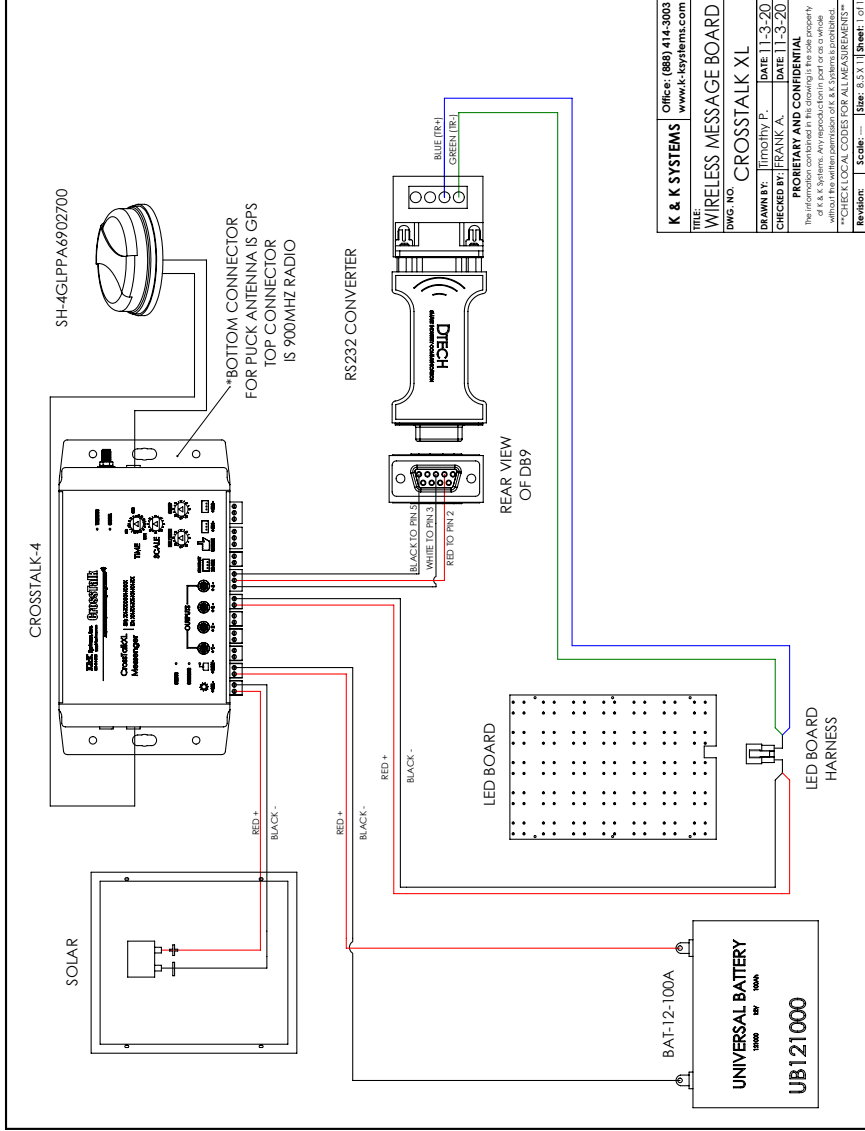

MESSAGE SIGN

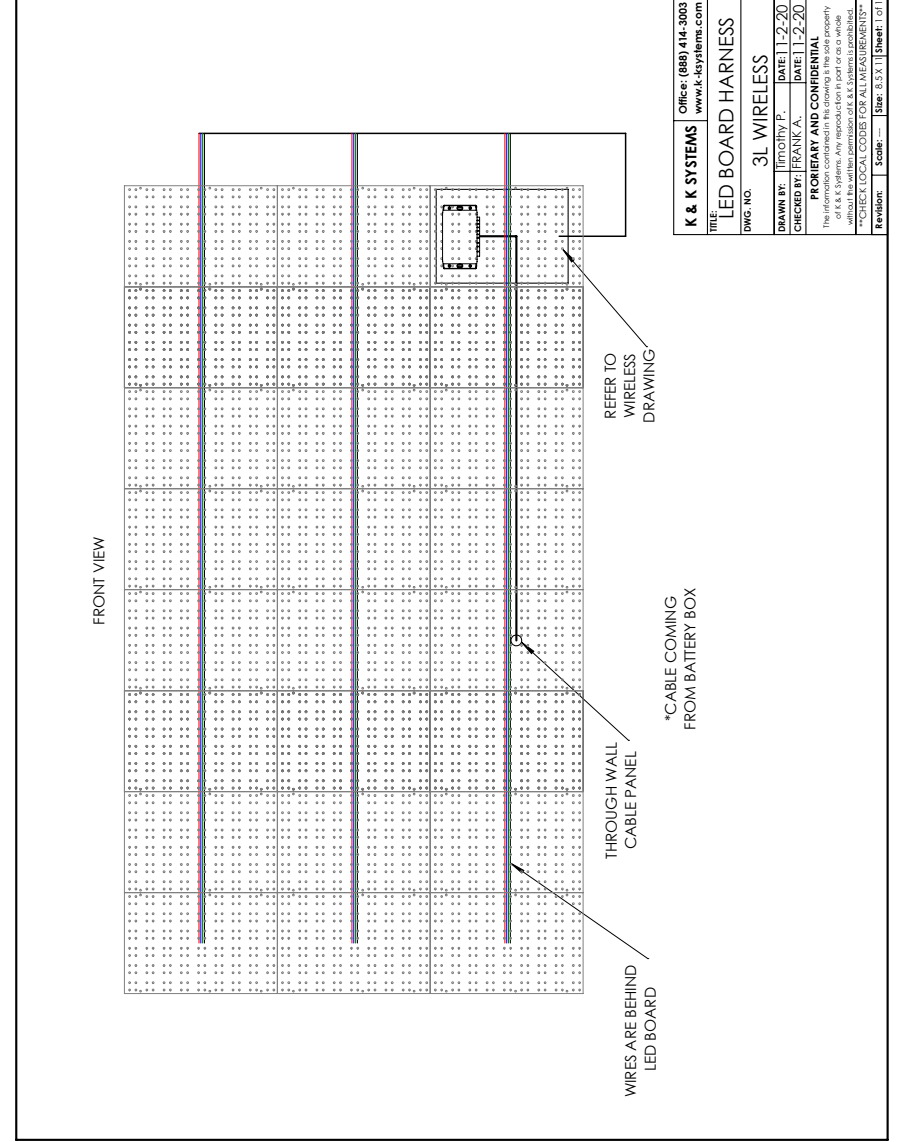

FRONT VIEW

A 1 on	B 2 on	C 1,2 on	D 3 on	E 1,3 on	F 2,3 on	G 1,2,3 on	H 4 on
J 1,7 on	K 2,7 on	L 1,2,7 on	M 3,7 on	N 1,3,7 on	O 2,3,7 on	P 1,2,3,7 on	Q 4,7 on
R 1,8 on	S 2,8 on	T 1,2,8 on	U 3,8 on	V 1,3,8 on	W 2,3,8 on	X 1,2,3,8 on	Y 4,8 on

*TYPE ONE LETTER PER BOARD IN A CUSTOM MESSAGE TO HELP WITH SETTINGS DIP SWITCHES
*SKIP THE LETTER "I" AS IT DISPLAYS UNEVENLY.

DESIGNED BY: FRANK A. LA	DATE: 07/11/2020	K & K SYSTEMS	Office: (622) 546-2025 www.k-systems.com
PROPRIETARY AND CONFIDENTIAL		TITLE: 9001 DIP SWITCHES	
The information contained in this drawing is the sole property of K & K Systems. Any reproduction in part or as a whole without the written permission of K & K Systems is prohibited.			
DWG. NO. 3 L DIP SWITCHES		Not located Size: 8.5 X 11 Sheet: 1 of 1	

FRONT VIEW

A	B	C	D	E	F	G	H
J	K	L	M	N	O	P	Q
R	S	T	U	V	W	X	Y

START HERE → ← END HERE

*DIP SWITCH NOT TO SCALE
EXAMPLE OF LETTER "A"

*TYPE ONE LETTER PER BOARD IN A CUSTOM MESSAGE TO HELP WITH SETTINGS DIP SWITCHES
*SKIP THE LETTER "I" AS IT DISPLAYS UNEVENLY
*START FROM LEFT SIDE AND WORK TOWARDS THE RIGHT

K & K SYSTEMS	Office: (888) 414-3003 www.k-systems.com
TITLE: 9002 DIP SWITCHES	
DWG. NO.	
DRAWN BY: Timothy P.	DATE: 11-24-20
CHECKED BY: FRANK A.	DATE: 11-24-20
PROPRIETARY AND CONFIDENTIAL	
The information contained in this drawing is the sole property of K & K Systems. Any reproduction in part or as a whole without the written permission of K & K Systems is prohibited.	
CHECK LOCAL CODING FOR ALL DIMENSIONS	
Revision:	Scale: --- Size: 8.5 X 11 Sheet: 1 of 1

DIP SWITCHES SETTINGS FOR MB9757 AND MB8249

FRONT VIEW

A 1 on	B 2 on	C 1,2 on	D 3 on	E 1,3 on	F 2,3 on	G 1,2,3 on	H 4 on
J 1,6 on	K 2,6 on	L 1,2,6 on	M 3,6 on	N 1,3,6 on	O 2,3,6 on	P 1,2,3,6 on	Q 4,6 on
R 1,7 on	S 2,7 on	T 1,2,7 on	U 3,7 on	V 1,3,7 on	W 2,3,7 on	X 1,2,3,7 on	Y 4,7 on

DRAWN	NAME	DATE	Office: 6429-544-2025
CHECKED	MICHAEL TAYLOR	1/11/19	www.k-systems.com
PROPRIETARY AND CONFIDENTIAL The information contained in this drawing is the sole property of K & K Systems. Any reproduction in part or as a whole without the written permission of K & K Systems is prohibited.			
K & K SYSTEMS		TITLE: 3 L DIP SWITCHES	
DWG. NO.		Not scaled	
		Sheet: 1 of 1	

*TYPE ONE LETTER PER BOARD IN A CUSTOM MESSAGE TO HELP WITH SETTINGS DIP SWITCHES
*SKIP THE LETTER "I" AS IT DISPLAYS UNEVENLY.

CUSTOM MESSAGE LOG

Record your custom programmed messages below. Numbers 1-16 will automatically be accessible from the **Quick Selection Thumb Wheel**.

QUICK SELECTION LIST

1		17
2		18
3		19
4		20
5		21
6		22
7		23
8		24
9		25
10		26
11		27
12		28
13		29
14		30
15		31
16		32
		33
		34
		35
		36
		37
		38
		39
		40

41	71
42	72
43	73
44	74
45	75
46	7
47	6
48	77
49	78
50	79
51	80
52	81
53	82
54	83
55	84
56	85
57	86
58	87
59	88
60	89
61	90
62	91
63	92
64	93
65	94
66	95
67	96
68	97
69	98
70	99



MANUFACTURER'S WARRANTY

1. The manufacturer warrants that all products manufactured by K&K Systems, Inc. will be free from defects in material and workmanship for a period of one (1) year from date of shipment, subject to the conditions and restrictions contained herein.
2. This warranty does not apply to a product that has not been installed or maintained in accordance with the manufacturer's instructions, has been subjected to damage in an accident, abused or neglected during operation, repaired or modified by persons other than manufacturer, its employees or authorized agents, or failed to have normal maintenance.
3. The buyer expressly agrees that the buyer's sole remedy and the manufacturer's sole responsibility, in respect to a warranty claim, is exclusively limited to repair or replacement at the manufacturer's option, of product or a portion thereof found by the manufacturer to be defective. The manufacturer is not responsible for labor or other expended charges by buyer including transportation charges, and shall not be liable for any incidental or consequential damages connected with repair of a product deemed to be defective or with installation or replacement of repaired product. Further, the manufacturer disclaims any liability for any incidental or consequential damages, including lost or duplicated time or expense accruing for any reason, to the owner or user or any products sold by the manufacturer, whether claim is made in contract or in tort or under any theory of warranty, negligence or otherwise.
4. The manufacturer reserves the right to make changes in its products from time to time, without incurring any obligation to incorporate such improvements in any products previously sold or in service.
5. The terms and conditions of the warranty cannot be altered without the written consent of the manufacturer.
6. The foregoing warranty is exclusive and in lieu of all other express, statutory and implied warranties **INCLUDING THOSE OF MERCHANTABILITY AND FITNESS FOR ANY PARTICULAR PURPOSE**. There are no warranties which extend beyond the language in the previous six (6) paragraphs.

If you have any further questions, please feel free to call us at our toll-free number, 888-414-3003, email info@k-systems.com or look us upon the internet at www.k-systems.com.



K&K Systems, inc.
Traffic Safety Products Manufacturer

687 Palmetto Rd.
Tupelo, Mississippi 38801

office: 662.566.2025
fax : 662.566.7123
toll-free: 888.414.3003

email: sales@k-systems.com
www.k-systems.com